

THE NEW EU FISCAL GOVERNANCE FRAMEWORK: A QUANTUM LEAP OR ONLY SMALL STEPS AHEAD?

BY GERRIT B. KOESTER, PHILIPP MOHL AND AD VAN RIET ¹

PAPER SUBMITTED TO THE
“10TH EUROFRAME CONFERENCE ON
ECONOMIC POLICY ISSUES IN THE EUROPEAN UNION”
WARSAW, 24 MAY 2013

THIS PRELIMINARY VERSION: 3 FEBRUARY 2013

PLEASE DO NOT QUOTE

ABSTRACT

The build-up of severe macroeconomic, financial and fiscal imbalances within the euro area, and the following sovereign debt crisis in several euro area countries resulted in the most comprehensive set of governance reforms at the European level since the introduction of the single currency. Against this background, this paper reviews and assesses the key changes of the EU fiscal governance framework. The paper concludes that the reforms of EU fiscal governance represent welcome steps in the right direction. However, the framework's effectiveness and credibility remain subject to a strict implementation of fiscal policy surveillance by the Commission and a limited use of political discretion by the Council, it does not effectively ensure downward debt trajectories and it continues to lack instruments for situations in which Member States refuse to comply with the rules. Looking further ahead, more ambitious steps towards improving the EU fiscal governance framework, in particular for euro area countries, will be necessary to address the remaining shortcomings and to realise a quantum leap – making the fiscal framework fully commensurate to the requirements of the single currency.

¹ All authors are with the European Central Bank, Directorate General Economics; Gerrit B. Koester, Fiscal Policies Division (gerrit.koester@ecb.europa.eu), Philipp Mohl, Fiscal Policies Division (philipp.mohl@ecb.europa.eu), Ad van Riet, Directorate Monetary Policy (ad.van_riet@ecb.europa.eu). The views presented are those of the authors and not those of the ECB. The authors are grateful to Roberta de Stefani and Jose Federico Geli Manzano (both Fiscal Policies Division) for their valuable input and support.

1. INTRODUCTION

The build-up of severe macroeconomic, financial and fiscal imbalances within the euro area, and the following sovereign debt crisis in several euro area countries called for a decisive reinforcement of the EU economic governance framework, in particular for the euro area, to ensure the stability and smooth functioning of EMU. Under the Treaty on the Functioning of the European Union (the Treaty, or TFEU), monetary policy is conducted at the supranational EU level, while fiscal, financial and structural policies have largely remained in the hands of the national governments. A price stability-oriented monetary policy alone is therefore not sufficient for a proper functioning of EMU and needs to be accompanied by sound policies in other domains (see ECB, 2008). Here fiscal policies play a crucial role, as unsound fiscal policies can interfere with an efficient conduct of monetary policy and unsustainable public finances can endanger the stability of the single currency.

For this reason, the Treaty and the Stability and Growth Pact (SGP) stipulate that euro area Member States have the obligation to avoid excessive government deficits and to “maintain sound and sustainable public finances”. To this end, the preventive arm of the SGP obliges Member States to maintain or to adjust towards their respective medium-term budgetary objective (MTO), while the corrective arm of the SGP should ensure the correction of excessive deficits in case they still occur.

However, the SGP did not succeed in securing fiscal discipline. Good economic times before the crisis were not used to achieve sustainable budgetary positions. Revenue windfalls were spent instead of being used to foster fiscal consolidation, violations of the deficit criterion were only slowly corrected and the debt criterion was largely ignored. The most important reason for this failure was that the SGP was only implemented half-heartedly as enforcement of the fiscal rules through peer pressure was weak. The procedures for addressing non-compliance lacked automaticity and thus left too much room for discretion. Financial sanctions have, in fact, never been imposed.

The lacking enforcement of the SGP was accompanied by only minimal differentiation in financial markets with respect to the interest rates on sovereign debt of euro area countries, resulting in only weak market discipline on fiscal policies in EMU. As a consequence, public finances of many euro area Member States were ill-prepared when the financial crisis erupted in the summer of 2007 (for a discussion see for example van Riet (ed.), 2010). The following deep economic downturn, the working of automatic stabilisers, fiscal stimuli programmes and support for the financial sector led to a strong deterioration of public finances in many euro area Member States and ultimately to a sovereign debt crisis in some of them.

The sovereign debt crisis has demonstrated that unsustainable macroeconomic, financial and fiscal policies of any EMU member amplify each other and affect other euro area countries

via negative spillover effects. This, in turn, endangers the financial stability of the euro area as a whole. As a consequence, the ECB repeatedly demanded a ‘quantum leap’ in the EU economic governance framework to ensure the stability and smooth functioning of EMU (see for example ECB, 2011). Countries must recognise their joint responsibility for stability and prosperity in the euro area, which requires the setting-up of effective institutions.

Against this background, EU and euro area leaders reacted to the challenges following from severe macroeconomic, financial and fiscal imbalances within the euro area in several incremental steps, inter alia, by introducing the European Semester, undertaking additional policy commitments in the Euro Plus Pact, and implementing six legislative changes to strengthen the EU economic governance framework (commonly referred to as the ‘six-pack’, which entered into force in December 2011) (see Figures 1 and 2).

Fig. 1 – Overview of the EU economic governance framework after the six-pack

Fiscal framework EU	Stability and Growth Pact (SGP)	<p>SGP preventive arm</p> <ul style="list-style-type: none"> • Definition of country-specific MTOs (structural balance) • Review of annual SCPs based on developments of structural balance, expenditure and government debt • Evaluation of compliance with adjustment path towards MTO and possibility of financial sanctions (interest bearing deposit) <p>SGP corrective arm</p> <ul style="list-style-type: none"> • Surveillance of compliance with deficit and debt criterion (3% and 60%) • Decisions on existence of excessive deficit based on deficit and/or debt • Recommendations for correction of excessive deficits • Possibility of financial sanctions (non-interest bearing deposit and/or fines) 	"six pack"
	National fiscal frameworks	<ul style="list-style-type: none"> • Mandatory minimum requirements (accounting and statistics, forecasts, numerical fiscal rules, medium-term budgetary frameworks, transparency) 	
	Statistical governance	<ul style="list-style-type: none"> • Minimum requirements for the independence of national statistical authorities and possibility of sanctions 	
Macroeconomic framework EU	Macroeconomic Imbalances Procedure (MIP)	<ul style="list-style-type: none"> • Stronger surveillance of imbalances: Early warning "scoreboard", country specific qualitative analysis • Excessive imbalance procedure: corrective plan with possibility of fines 	
	European semester	<ul style="list-style-type: none"> • Reporting of budget proposals to the EU COM, non-binding recommendation of EU COM 	
Policy coordination EU/EA	Euro+ Pact	<ul style="list-style-type: none"> • Strengthening economic coordination for competitiveness, employment, fiscal sustainability and financial stability 	

Source: Own illustration.

The ‘six-pack’ includes the reform of both the preventive and corrective arms of the Stability and Growth Pact, the new minimum requirements for national budgetary frameworks, the new Macroeconomic Imbalance Procedure (MIP), and a stronger enforcement mechanism through new financial sanctions, under both the SGP and the MIP (see Figure 2).

Fig. 2 – The ‘six-pack’

	Fiscal	Macroeconomic
Surveillance	<ul style="list-style-type: none"> • Regulation 1175/2011 on the strengthening of the surveillance of budgetary positions (former Reg. 1466-97) → Preventive arm of the SGP: expenditure rule and consideration of debt • Regulation 1177/2011 on speeding up and clarifying the implementation of the EDP (former Reg. 1467-97) → Corrective arm: equal footing of the government debt criterion • New EC Directive 2011/85/EU on requirements for budgetary frameworks of the MS → Minimum requirements for national fiscal frameworks 	<ul style="list-style-type: none"> • New Regulation 1176/2011 on the prevention and correction of macroeconomic imbalances → Early warning “scoreboard”, country specific qualitative analyses → Excessive imbalance procedure
Enforcement	<ul style="list-style-type: none"> • New Regulation 1173/2011 on the effective enforcement of budgetary surveillance in the euro area (EA) → Financial sanctions for euro area MS in case of non-compliance with the fiscal rules (at an earlier stage and gradually increasing), decided quasi-automatically 	<ul style="list-style-type: none"> • New Regulation 1174/2011 on enforcement measures to correct excessive macro-economic imbalances → Financial sanctions possible

Source: Own illustration.

As concerns about the credibility of fiscal policies, the stability of the financial sector and the longer term economic growth conditions in the euro area countries remained, and market tensions in a number of countries continued against the background of high short-term refinancing needs, the euro area Heads of State or Government agreed on 26 October 2011 on a further strengthening of the fiscal framework. It took only until 2 March 2012, when the Heads of State or Government of all EU Member States with the exception of the United Kingdom and the Czech Republic signed the Treaty on Stability, Coordination and Governance in the Economic and Monetary Union, which includes the fiscal compact, a fostering of economic policy coordination and convergence as well as measures related to euro area governance (for a summary of the main elements see Figure 3). As two Member States were not willing to commit to the TSCG, it takes the form of an intergovernmental agreement among contracting parties, which will enter into force after 12 euro area countries have ratified it. At the time of writing, it has been ratified by 10 euro area countries. The intention is to incorporate the substance of the TSCG into the EU Treaties within at most five years following its entry into force.

Fig. 3 – The Treaty on Stability, Coordination and Governance in the EMU

Title III: Fiscal compact	<ul style="list-style-type: none"> • Balanced budget rule including an automatic correction mechanism to be implemented in national law • Strengthening of the excessive deficit procedure • Enshrines the numerical benchmark for debt reduction for Member States with government debt exceeding 60% of GDP • Ex-ante reporting on public debt issuance plans
Title IV: Economic policy coordination and convergence	<ul style="list-style-type: none"> • Commitment to take additional policy actions fostering a smooth functioning of EMU and economic growth through enhanced convergence and competitiveness • Ex-ante discussion and, where appropriate, coordination of major economic policy reforms to benchmark best practices
Title V: Governance of the euro area	<ul style="list-style-type: none"> • Organisation of Euro Summit meetings at least twice per year • Conference of representatives of relevant committees of both the national parliaments and the European Parliament on the issues covered by the TSCG

Source: Own illustration.

The third important reform pillar – accompanying ‘six-pack’ and fiscal compact – is the so-called ‘two-pack’, which refers to two additional EU regulations proposed by the Commission in November 2011 to further step-up surveillance of euro area countries. These two regulations, in particular aim at keeping a closer eye on whether they continue to observe the agreed EU fiscal rules and to move on to more intrusive surveillance if they get into financial difficulties (see Figure 4). The ‘two-pack’ regulations have entered dialogue negotiations between the EU Council, the European Commission and the European Parliament and are expected to be finalised at the end of 2012.

Fig. 4 – The ‘two-pack

Proposed regulation on monitoring draft budgetary plans Reg. COM(2011) 821 final	
Budgetary regulation	<ul style="list-style-type: none"> • Enhance the budgetary surveillance of draft budgetary plans by the European Commission • Closer monitoring procedures to ensure the correction of excessive deficits
Proposed regulation on strengthening surveillance procedures Reg. COM(2011) 819 final	
Stability regulation	<ul style="list-style-type: none"> • Lays down a surveillance mechanism applicable to euro area Member States experiencing or threatened with financial market tensions and/or receive financial assistance • Involvement of the ECB and European Supervisory Authorities

Source: Own illustration.

Taken together, these legislative changes and policy decisions represent the most comprehensive set of governance reforms at the European level since the introduction of the single currency.

This paper first reviews the key changes of the EU fiscal governance framework focusing on (the fiscal elements of) the ‘six-pack’ (Chapter 2), the fiscal compact (Chapter 3) and the ‘two-pack’ (Chapter 4). In a second step, the paper assesses in Chapter 5 whether the reinforced EU fiscal framework has really strengthened fiscal governance.

2. STRONGER SURVEILLANCE AND ENFORCEMENT: THE ‘SIX-PACK’

2.1 Overview

The ‘six-pack’ includes the reform of both the preventive and corrective arms of the Stability and Growth Pact (see Figure 5 for an overview of the SGP). Under the preventive arm of the SGP, Member States are committed to reach a country-specific medium-term budgetary objective of a structural deficit close to balance or in surplus. The aim of the MTO is threefold: (i) to preserve a safety margin with respect to the 3% of GDP reference value for the government deficit; (ii) to ensure rapid progress towards sustainable public finances and prudent debt levels; and thus (iii) to allow room for budgetary manoeuvre, in particular so as to accommodate public investment needs. The Member States’ commitment is monitored by the Commission and the Council on the basis of the Stability and Convergence Programmes – which must be submitted annually by Member States – as well as ex post fiscal data. The purpose of the corrective arm of the SGP is to remedy policies, which put fiscal sustainability at risk. Non-compliance with the Maastricht criteria, i.e. deficits larger than 3% of GDP and/or a debt level exceeding 60% of GDP, can trigger an excessive deficit procedure (EDP). Member States then have to take effective action within a certain time period regarding recommendations prepared by the Commission and decided by the Council.

Against this background, this chapter reviews and assesses the major fiscal elements of the ‘six-pack’ and their implications for both the preventive and the corrective arm of the SGP.

Fig. 5 – The preventive and corrective arm of the reinforced SGP

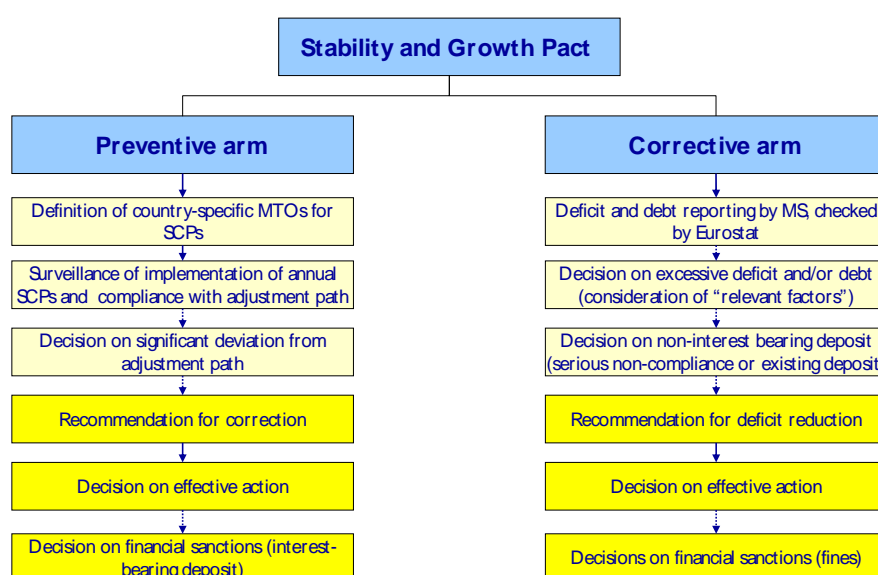

Source: Own illustration.

2.2 The effects on the preventive arm

Within the six-pack, especially EU regulation 1175/2011 (former regulation 1466-97) on the strengthening of the surveillance of budgetary positions (henceforth: *the preventive regulation*) seeks to reinforce the preventive arm of the SGP. Five major innovations of procedures in the preventive arm of the SGP can be identified.

i) Council can invite Member State to strengthen adjustment path of the SCP

The preventive arm consists especially of two procedures: the ex ante assessment of the Stability and Convergence Programmes and the ex post assessment of deviations from fiscal adjustments path for countries, which have not yet reached their MTO (see Figure 6). With respect to the first procedure, the preventive regulation introduces the additional possibility for the Council to issue ex ante an opinion on the adjustment path as defined in the Stability and Convergence Programme. This opinion can – if necessary – invite a Member State to strengthen the fiscal adjustment path. The main steps of the ex post procedure remain unchanged, but the procedure now includes the possibility to impose a financial sanction (discussed in more detail below).

Fig. 6 – Main assessment of procedures under the preventive arm

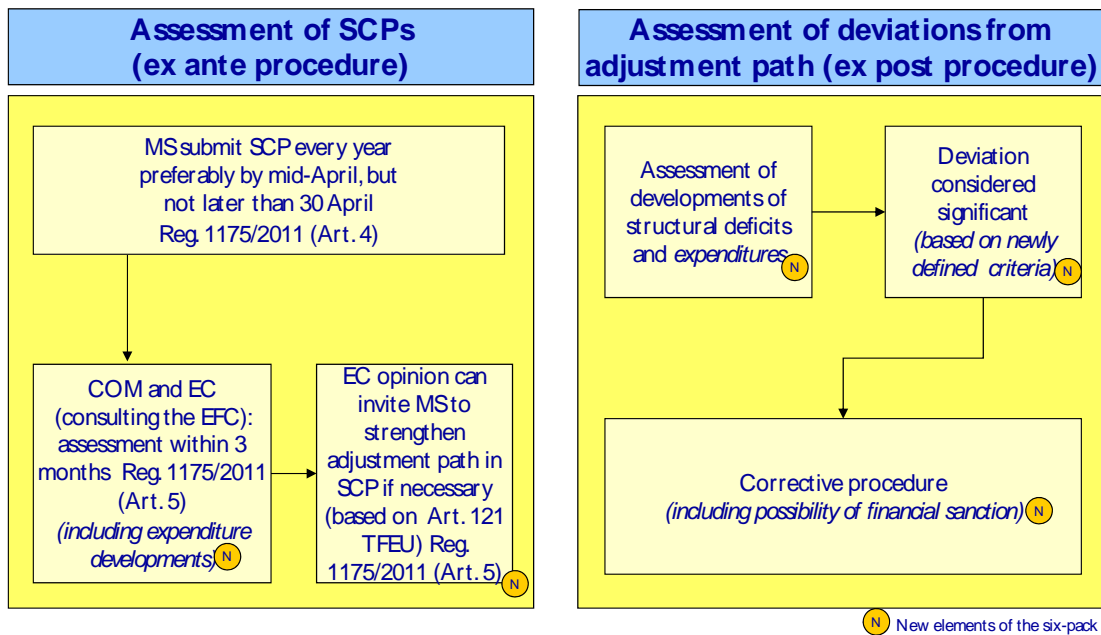

Source: Own illustration.

ii) Determination of consolidation requirements takes debt levels into account

When defining the adjustment process to the MTO, the preventive regulation requires that the debt-to-GDP ratio is taken into consideration in both the ex ante and the ex post procedure of the preventive arm. Member States, which have not yet reached their MTO and record a debt ratio above 60% of GDP, are required to improve their structural balance by more than 0.5% of GDP per year. Compared to the standard requirement of an annual improvement of the structural balance by 0.5% of GDP per year, this slightly increases the consolidation requirements for countries with high debt ratios (see Figure 7).

Fig. 7 – Taking debt ratio into consideration for determining consolidation requirements

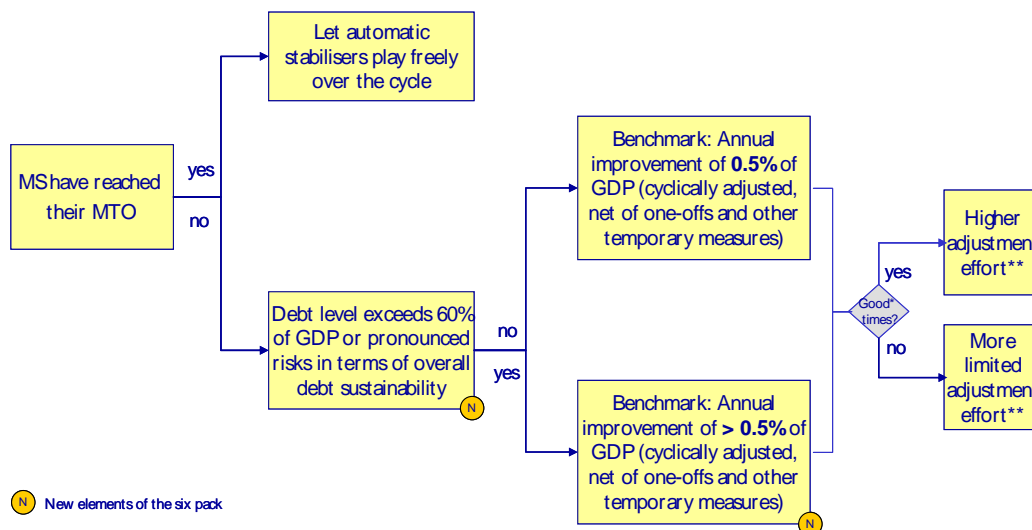

Legal basis: Amended Regulation 1466/97 Art. 5 based on Art. 121(6) TFEU.

"In principle, good times should be identified as periods where output exceeds its potential level." CoC, 9th Dec 2011, p.6.

** "Revenue wind- and shortfalls should be taken into account. Windfall tax revenues should be understood as revenues in excess of what can normally be expected from economic growth." CoC, 9th Dec 2011, p.6.

Source: Own illustration.

iii) Introduction of an expenditure rule

While the preventive arm focused in the past exclusively on the development of the structural balance, the preventive regulation introduced in addition an expenditure rule. This rule – which is included in the ex ante as well as in the ex post procedure – requires that the adjusted primary expenditure must not exceed potential medium-term GDP growth (see Figure 8).

Fig. 8 – The new expenditure rule: definition and essential elements

Goals	<ul style="list-style-type: none"> ensures properly financing of expenditure increases assigns revenue windfalls to reduce the deficit/debt
Expenditure	<ul style="list-style-type: none"> primary expenditure (net of expenditure on Union programmes fully matched by Union funds revenue, non-discretionary changes in unemployment benefit expenditure, discretionary revenue measures, revenue increases mandated by law; additionally: 4 year averaging of capital expenditure especially for small MS)
Benchmark	<ul style="list-style-type: none"> growth of expenditure should not exceed potential medium-term GDP growth (based on the 5 previous, the current and the following 4 years) Increases in government expenditure in excess of medium-term growth need to be matched by additional discretionary revenue increases Additional discretionary revenue decreases need to be compensated by lower growth of expenditure
Example	<ul style="list-style-type: none"> relevant government expenditure equals 25% of GDP and grows by 3% potential medium-term GDP growth 1% → negative impact of expenditure on government balance of 0.5% of GDP (to be considered in assessment of significant deviation)

Source: Own illustration.

Fig. 9 – Application of the new expenditure rule

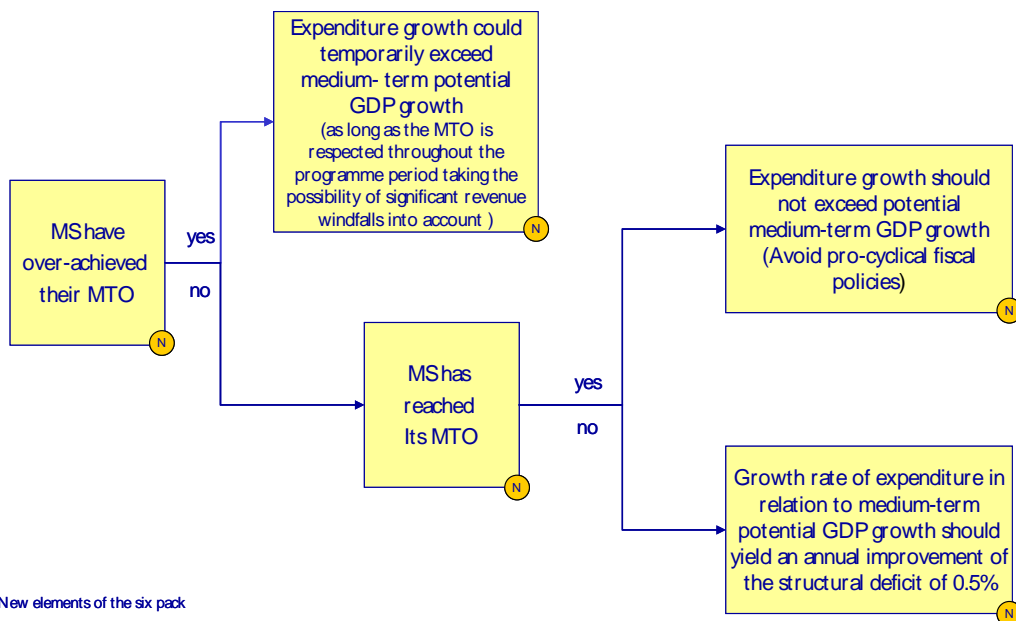

New elements of the six pack

Legal basis: Regulation 1175/2011 Art. 5 based on Art. 121(6) TFEU; CoC, 9th Dec, p.6.

Source: Own illustration.

The expenditure rule receives a prominent role within the preventive arm (see Figure 9). Only if a Member state has overachieved its MTO, expenditure growth is allowed to temporarily exceed its medium-term potential GDP growth. If a country has reached but not overachieved its MTO, expenditure growth should not exceed medium-term GDP growth to avoid procyclical fiscal policies. Finally, for countries which are still on the adjustment path to their MTO, expenditure developments should yield an annual improvement of the structural deficit of 0.5%, effectively promoting expenditure-based consolidation.

iv) Explicit definition of significant deviations from the MTO or the adjustment path towards it

For an effective fiscal surveillance under the preventive arm, clearly defined criteria for assessing compliance are necessary for the ex ante as well as for the ex post procedure.

Fig. 10 – Defining significant deviations from the MTO or the adjustment path

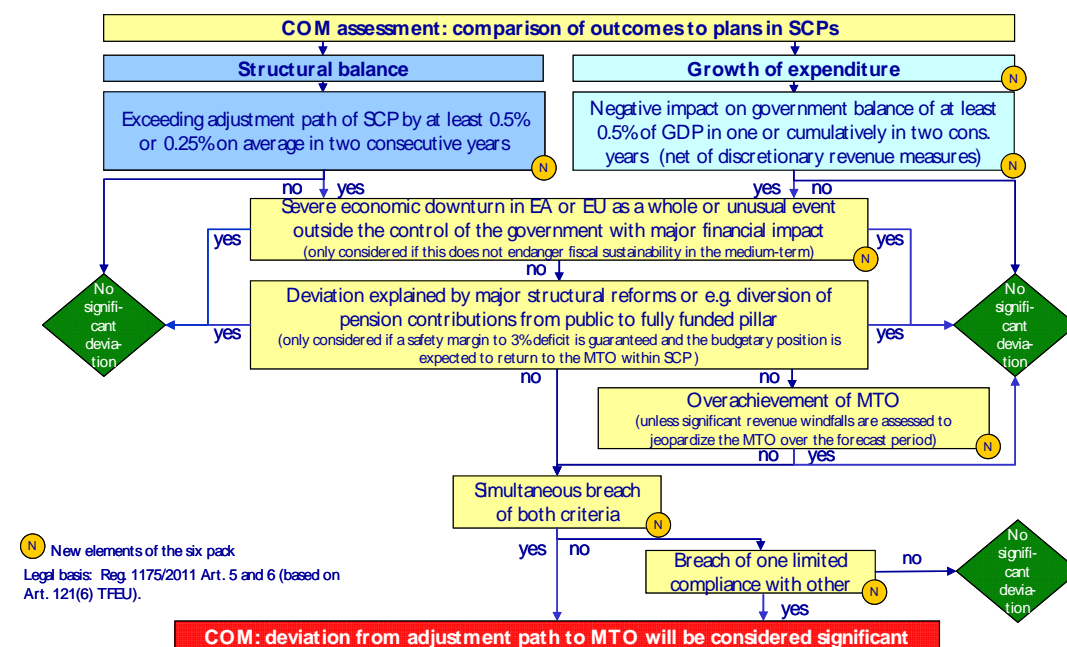

Source: Own illustration.

In this respect the preventive regulation specifies significant deviations with respect to the structural balance as well as with respect to expenditure developments (see Figure 10). An observed deviation with respect to the adjustment path is considered significant for the structural balance, if it exceeds the adjustment path by at least 0.5% of GDP in one year or one average by at least 0.25% in two consecutive years. Growth of expenditure counts as a significant deviation if the negative impact on the governance balance is at least 0.5% of GDP in one year or 0.5% of GDP cumulatively in two consecutive years (net of discretionary measures). However, non-compliance with only one of the criteria is not sufficient to consider a deviation from the adjustment path as significant. For this the simultaneous breach of both

criteria or the breach of one and only limited compliance with the other are required.² Furthermore, deviations are not considered significant if one of the two escape clauses applies (see Figure 10).

v) Strengthening the procedure following significant deviations from the MTO

The preventive regulation also strengthens the procedure, which is triggered by a significant deviation from the MTO or the adjustment path towards it in the ex post procedure of the preventive arm (see Figure 11). Especially three innovations should be stressed: first, the Commission is now allowed to issue a warning directly after it has diagnosed a significant deviation. Second, if the Council does not follow the Commission recommendation to decide that ‘no effective action’ has been taken with qualified majority of euro area Member States without the Member State concerned, then the Commission can submit a renewed recommendation. This is passed unless at least 9 euro area Member States of the Council vote against it (known as “reversed simple majority voting”). The third innovation is the introduction of a financial sanction in the form of an interest-bearing deposit of 0.2% of GDP, which can be proposed by the Commission if no effective action has been taken. This sanction is automatically approved unless the Council rejects the recommendation of the Commission by qualified majority (known as ‘reverse qualified majority voting’).

Fig. 11 – The procedure triggered in case of a significant deviation from the MTO

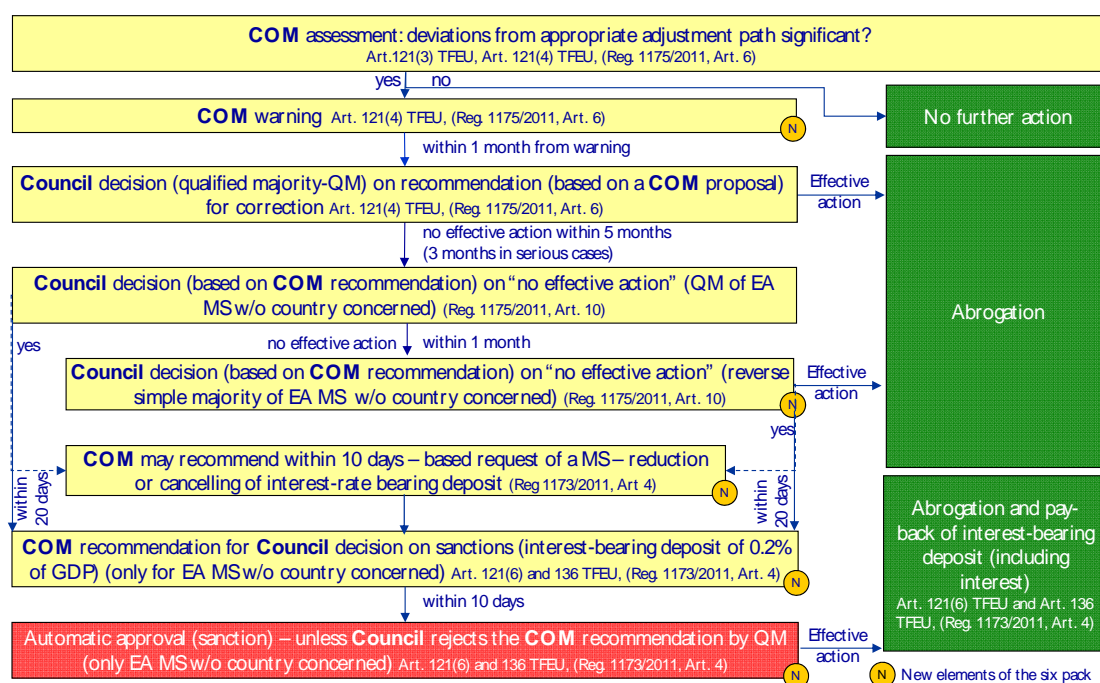

Source: Own illustration.

² This could imply that deviations of the structural budget balance from the MTO or the adjustment path towards it alone are not sufficient for a significant deviation if the country still complies with the expenditure criterion.

2.3 The effects on the corrective arm

The reinforced corrective arm of the SGP, based on EU regulation 1177/2011 (former regulation 1467/97; hencefort: *the corrective regulation*), introduces several elements to strengthen the excessive deficit procedure. Furthermore, regulation 1173/2011 sets the rules on how the budgetary surveillance in the euro area is enforced and financial sanctions are decided by the decision-making bodies. (hencefort: *the enforcement regulation*). Four major innovations of a procedures in the corrective arm of the SGP can be identified.

(i) Introduction of a new numerical benchmark for debt reduction

Since its creation, the SGP has foreseen the possibility to start an excessive deficit procedure based on the debt criterion. Article 126 of the TFEU stipulates that such a procedure can be started if “the ratio of government debt to gross domestic product exceeds a reference value, unless the ratio is sufficiently diminishing and approaching the reference value at a satisfactory pace.” One reason why the debt criterion has played nearly no role in past excessive deficit procedures is that it remained relatively vague with respect to the debt reduction that is required for countries with a debt ratio above 60% of GDP. To give the debt criterion a more prominent role the new corrective regulation specifies a concrete numerical benchmark for debt reduction: Member States are required to reduce their debt in excess of 60% of GDP by one twentieth per year.

Based on this benchmark, the corrective regulation specifies that in order for the Commission to initiate an EDP and to prepare a report on the existence of an excessive deficit according to Art. 126(3) TFEU the following four criteria have to be fulfilled (see Figure 12): (i) the current debt-to-GDP ratio must exceed 60% of GDP (step 1), (ii) it has not been sufficiently diminishing over the past three years (step 2), (iii) the missing sufficient reduction of debt cannot be explained by cyclical conditions³ and (iv) the debt-to-GDP ratio is not expected to sufficiently decline in the next year. The Commission can also prepare a report if it just sees a risk of an excessive deficit.

³ The cyclical conditions are checked with the following formula
$$\left(\frac{B_t}{Y_t}\right)^{3\text{-years-adjusted}} = \frac{B_t + \sum_{j=0}^2 C_{t-j}}{Y_{t-3} \prod_{h=0}^2 (1 + y_{t-h}^{\text{pot}})(1 + p_{t-h})}$$
, where B_t is the debt-to-GDP ratio in t , Y_t is the GDP at current prices, C_t is the cyclical part of the budget balance, which is derived from a production function approach, y_t^{pot} stands for the potential output growth and p_t is the price deflator of GDP.

Fig. 12 – Does an excessive debt-to-GDP ratio exist?

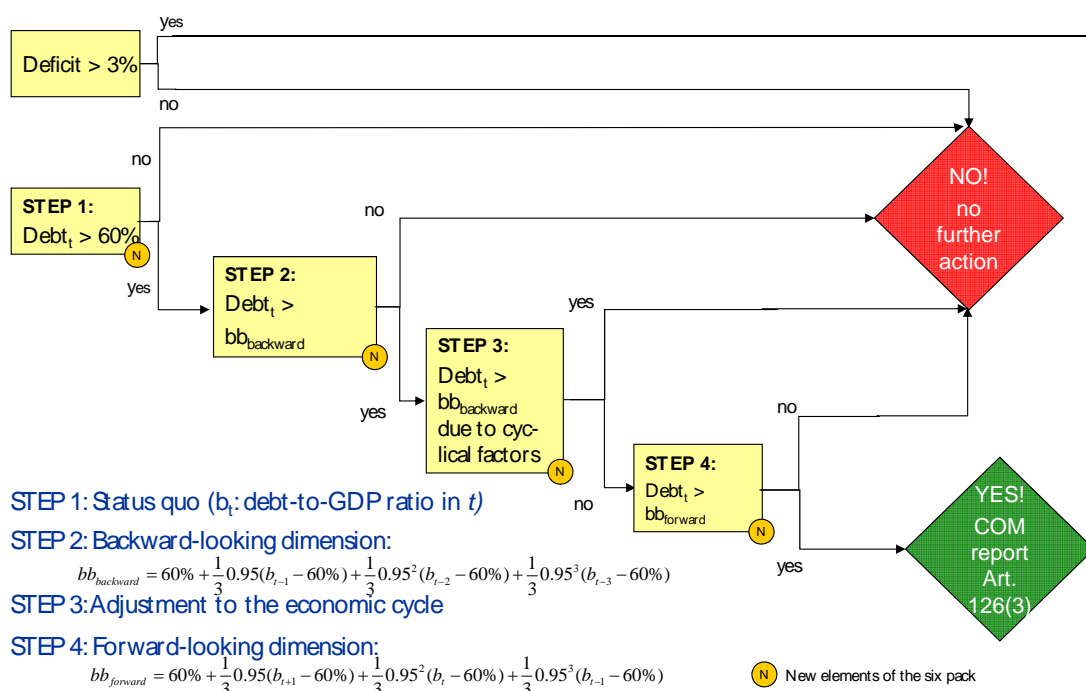

Note: see Art 2 regulation 1177/2011.

Source: Own illustration.

The numerical debt benchmark will be applied after a country specific transition period of three years following the abrogation of the EDPs ongoing in December 2011. During this transitional period, Member States have to make “sufficient progress towards compliance” with the new rule. This sufficient progress should be defined by a minimum linear structural adjustment path, ensuring that – if followed – Member States will comply with the debt rule at the end of the transition period. This adjustment path takes into account both the influence of the cycle and the forward-looking nature of the debt benchmark. In addition, Member States should respect simultaneously the following two conditions:

- the annual structural adjustment should not deviate by more than ¼% of GDP from the minimum linear structural adjustment ensuring that the debt rule is met by the end of the transitional period.
- at any time during the transition period, the remaining annual structural adjustment should not exceed ¾% of GDP.

Since EDPs started on the basis of the debt criterion will typically imply a longer deadline for correction (around three years), they should be only abrogated on the basis of notified past data, and not on the basis of forecasts. However, in order to ensure that compliance is sustained, the forward-looking dimension of the benchmark should also be respected.

(ii) No automaticity when deciding on the existence of an EDP

An EDP is not automatically opened if a Member State has an excessive deficit (based on the deficit- and/or debt-to-GDP ratio). Instead, the Commission is asked to prepare a report assessing all “relevant factors” (Art. 126(3) TFEU), before the Council decides by qualified majority whether the deficit and/or debt is excessive based on an overall assessment (Art. 126(6) TFEU). This overall assessment takes into account an extended list of ‘relevant factors’, which can be grouped in three areas (see Art. 2(3) Reg. 1177/2011):

- Developments in the medium-term economic position (in particular potential growth, including the different contributions provided by labour, capital accumulation and total factor productivity, cyclical developments and the private sector net saving position),
- Developments in the medium-term budgetary position (in particular, the record of adjustment towards the medium-term budgetary objective, the level of the primary balance and developments in primary expenditure, both current and capital, the implementation of policies in the context of the prevention and correction of excessive macroeconomic imbalances, the implementation of policies in the context of the common growth strategy of the Union and the overall quality of public finances, in particular the effectiveness of national budgetary frameworks),
- Developments in the medium-term government debt position, its dynamics and sustainability (in particular, risk factors including the maturity structure and currency denomination of the debt, stock-flow adjustment and its composition, accumulated reserves and other financial assets, guarantees, notably linked to the financial sector, and any implicit liabilities related to ageing and private debt, to the extent that it may represent a contingent implicit liability for the government).

Before the six-pack, relevant factors were in practice only to be applied, if the deficit-to-GDP ratio was below 3.5% and only temporarily above the 3% of GDP reference value. With the six-pack, relevant factors will now also be applied for higher and non-temporary deviations from the reference value as long as the debt ratio is below 60% of GDP. Furthermore, relevant factors are also considered for all EDPs that are started on the basis of the debt criterion. One should note that these relevant factors can aggravate or mitigate the fiscal situation and in the latter case may represent potential loopholes to avoid the start of an EDP,

Fig 13 – Consideration of relevant factors in Council’s decision on an excessive deficit (Art. 126(6) TFEU)

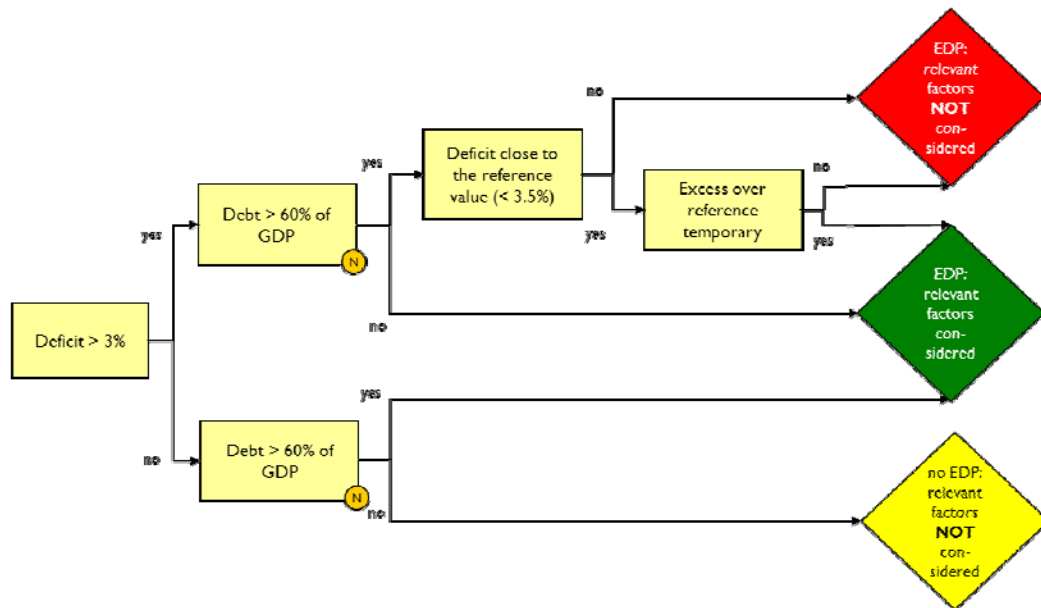

Note: In terms of the decision on the existence of an excessive deficit, relevant factors are always considered in the COM report (Art. 126(3) TFEU), but they will only be considered if the above conditions are met in the EFC opinion (Art. 126 (4) TFEU), COM opinion (Art. 126(5) TFEU) and EC decision (Art. 126(6) TFEU).

Source: Own illustration.

(iii) Increased peer pressure by possibility of surveillance missions

After the Council has decided that an excessive deficit exists (Art. 126(6) TFEU), a complex procedure starts (see Figure 14). The concrete steps of this procedure have been only slightly adjusted by the six-pack. The most important change introduced by the corrective regulation is that after the first decision on “no effective action” and all following steps of the procedure, the Commission can send out surveillance missions for the purpose of the assessment of the actual economic situation in the Member States and the identification of any risks or difficulties in complying with the objective (see Art. 10a of the corrective regulation).

Fig. 14 – Decision-making in the corrective arm of the EDP

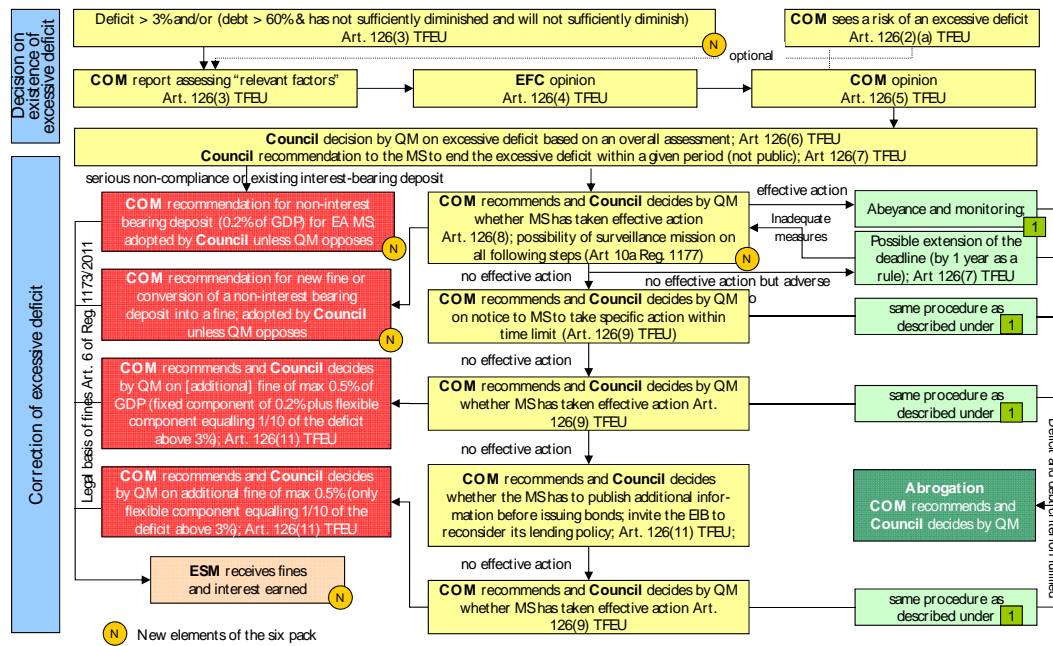

Source: Own illustration.

(iv) Enabling earlier financial sanctions (fines)

Compared with the SGP 2005, the reinforced SGP 2011 allows for earlier sanctions in case of persistent non-compliance with the Council’s recommendations or notices. If a deposit already exists from the preventive arm (see Figure 11) or in case of serious non-compliance by the Member State, the reinforced SGP foresees a non-interest bearing deposit already four months after the reporting date of the deficit-/debt-to-GDP ratios (see Figure 15). After seven months and repeated non-effective action, Member States can be fined or the non-interest bearing deposit can be converted into a fine. By contrast, according to the SGP 2005, a non-interest bearing deposit was only possible after 16 months.

The amount of the fine shall comprise a fixed component of 0.2% of GDP and a variable component (Art. 12 of the corrective regulation). The variable component shall amount to one tenth of the absolute value of the difference between the balances as a percentage of GDP in the preceding year and either the reference value for government balance or, if non-compliance with budgetary discipline includes the debt criterion, the government balance as a percentage of GDP that should have been achieved in the same year according to the notice issued under Art. 126(9) TFEU. In each year after the fine is imposed the Council assesses whether a Member State has taken effective action. If the Member States does not comply with the Council’s notice, the Council can decide on an additional fine, which shall be calculated in the same way as for the variable component described above.

Fig. 15: Possibility of sanctions according to SGP 2005 vs. SGP 2011

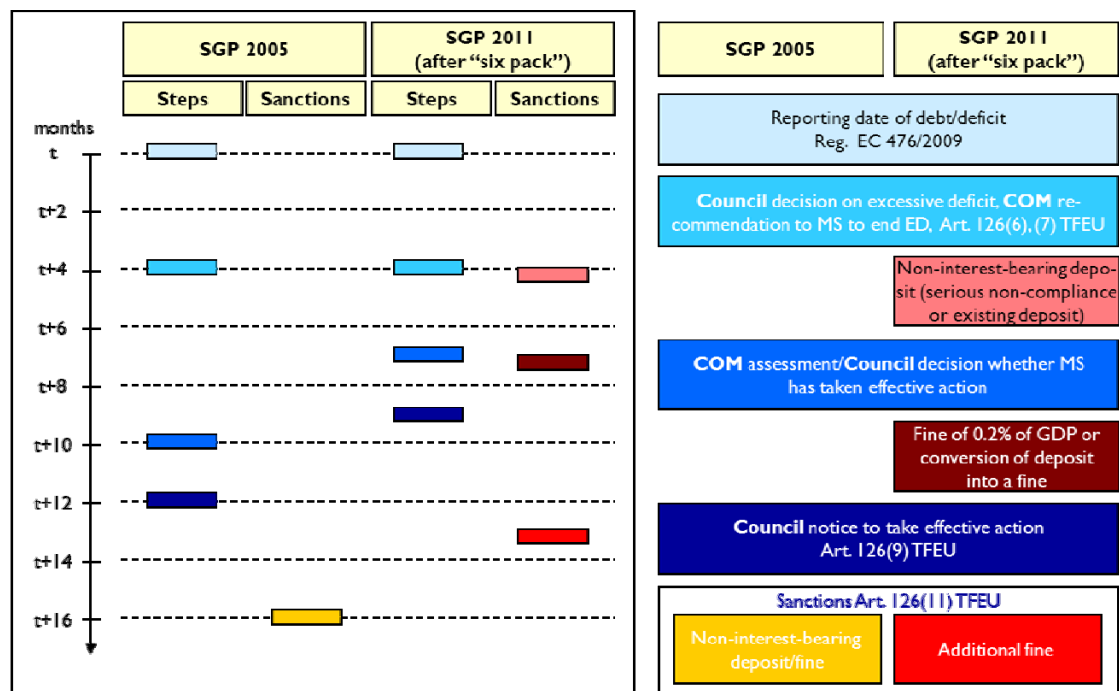

Source: Own illustration.

2.4 Assessment: strengths and remaining weaknesses of the EU fiscal framework after the 'six-pack' reform

The 'six-pack' includes important elements that strengthen the fiscal governance framework.

In the preventive arm, the possibility of the Commission to issue opinions on Stability and Convergence Programmes can contribute to create political pressure on governments and help to avoid the build-up of imbalances early on. Explicitly taking the debt criterion into account when defining the adjustment needs is a welcome step to integrate sustainability risks resulting from high debt ratios. The introduction of an expenditure rule and its prominent role in the preventive arm can help to ensure that good times are not wasted, as it helps to channel revenue windfalls into fiscal consolidation. The operationalisation of significant deviations from the adjustment path towards the MTO – based on the structural deficit and the expenditure rule – increases the transparency of surveillance in the preventive arm and can help to increase the bindingness of the rules. Furthermore, the strengthening of the procedure following significant observed deviations from the MTO or the adjustment path towards (by the possibility of issuing a warning right after the detection of significant deviations, the reductions of the majorities required for deciding on no effective action and the introduction of a financial sanction) can increase peer pressure and reduce the room for political discretion.

In the corrective arm, the introduction of a new numerical benchmark for debt reduction is very welcome, as it can help to give the debt criterion a more prominent position and stress

the importance of downward debt trajectories. The introduction of surveillance missions can help to increase political peer pressure. Finally, the possibility to apply new financial sanctions early on and the application of reverse qualified majority voting on financial sanctions can help to give the EDP teeth and limit the room for political discretion.

Despite these improvements of the EU fiscal governance framework, notably the following five key shortcomings remain.⁴

First, the large number of exceptional situations that can be taken into account weakens the application of the rules within the reinforced SGP. In the preventive arm, especially the newly introduced escape clause of a severe economic downturn in the euro area as a whole or an unusual event outside the control of the government with major financial impact has the potential to weaken the procedure. Furthermore significant deviations from both the structural deficit and the expenditure path need are necessary to start a sanctioning procedure. This could mean that deviations of the structural budget balance from the MTO or the adjustment path towards it alone are not sufficient for a significant deviation if the country still complies with the expenditure criterion. In the corrective arm, there is – in particular – a long list of relevant – in most cases mitigating – factors to be considered when deciding whether a deficit or debt-to-GDP ratio is excessive. Consequently, non-compliance with the deficit or debt criterion will not necessarily result in an excessive deficit procedure being launched. Moreover, since the 2011 reform of the SGP, such relevant factors are even taken into account if the deficit substantially exceeds the 3% of GDP ceiling while the country's debt ratio is below the 60% of GDP reference value.

Second, the enhanced EU fiscal framework still lacks sufficient automaticity in case of non-compliance with the rules. In particular, the Council continues to have substantial room for discretion under the reinforced SGP. For example, the Council – on the basis of an overall assessment – has to decide by qualified majority on the recommendation to correct a significant deviation from the adjustment path towards the MTO in the preventive arm or – in the corrective arm – that an excessive deficit exists. Without this decision, no financial sanctions are possible.

Third, the effectiveness of the reinforced EU fiscal framework still depends heavily on a strict and rigorous application of the rules by the Commission. For example, the Commission plays a decisive role in the assessment of the existence of an excessive deficit or of whether Member States have taken effective action to correct an excessive deficit. Another example is that the Commission can give a recommendation to the Council to reduce or cancel the new financial sanctions, either on grounds of exceptional economic circumstances or following a request by the euro area Member State concerned.

⁴ See the box entitled “Stronger EU economic governance framework comes into force”, Monthly Bulletin, ECB, December 2011.

Fourth, the reinforced EU fiscal framework is more complex, which might reduce its transparency as well as enforceability and, in turn, complicate accountability. In particular, the assessment of Member States' progress towards their respective MTOs requires a more complex analysis of both the structural budget balance and of expenditure net of discretionary revenue measures. In this context, it might be difficult to verify all the necessary data on time (e.g. with respect to detailed expenditure categories or the effects of discretionary revenue measures).

Finally, the agreed minimum benchmarks for national budgetary frameworks are insufficient. Most notably, the strengthening of the national fiscal frameworks will largely depend on the countries' political will to implement sound fiscal rules.

3. FISCAL COMPACT

3.1 Overview

The main goal of the fiscal compact is to foster fiscal discipline, notably in the euro area, building on and enhancing the reinforced SGP. It consists of two main modules: a balanced budget rule including an automatic correction mechanism, which is linked to the preventive arm of the SGP, and a strengthening of the excessive deficit procedure of the corrective arm. In the following the effects of the fiscal compact on the preventive and the corrective arm will be reviewed.

3.1 Effects on the preventive arm

The general provisions of the balanced budget rule in the fiscal compact are largely concordant with the EU regulations of the preventive arm of the SGP. In fact, the fiscal compact explicitly refers to it in the following three areas (see Table 1): the MTO, the escape clause and the assessment of compliance with the adjustment path.

First, the balanced budget rule refers explicitly to the MTO in the preventive arm of the SGP, which requires the general government budget to be close to balance or in surplus in structural terms and sets a structural deficit limit of 1% of GDP for euro area and ERM II countries. The fiscal compact in contrast sets a lower general limit of a structural deficit of 0.5% of GDP, while the limit can be increased to up to 1% of GDP only for countries with a government debt-to-GDP ratio significantly below 60% and with low risks to long-term fiscal sustainability. However, in practice, the new balanced budget rule will not be more ambitious than the EU regulation already demands, since all euro area countries currently have an MTO that equals a structural deficit of 0.5% of GDP or less.

Second, the definition of the escape clause in terms of exceptional circumstances is the same in the fiscal compact as in the preventive arm of the SGP. Exceptional circumstances are defined as a severe economic downturn in euro area or EU as a whole or an unusual event outside the control of the government with major financial impact. In addition, the detailed provisions of the latter also allow, under strict conditions, for larger deviations from the MTO or the adjustment path towards it in case of major structural reforms or pension reforms that benefit fiscal sustainability in the longer term.

Third, whether observed deviations from the balanced budget target or the convergence path towards it are considered significant will be evaluated on the basis of an overall assessment with the structural balance as a reference, including an analysis of expenditure net of discretionary revenue measures, thereby following the provisions of the reinforced SGP.⁵

Table 1: Comparison of the preventive arm of the reinforced Stability and Growth Pact with the balanced budget rule of the fiscal compact

	Revised Stability and Growth Pact (preventive arm)	Fiscal Compact (balanced budget rule)
Legal basis	<ul style="list-style-type: none"> Secondary EU law 	<ul style="list-style-type: none"> Primary law (intergovernmental and national level)
Budgetary objective	<ul style="list-style-type: none"> Close to balance or in surplus Country-specific MTO: maximal structural deficit of 1% of GDP for euro area countries 	<ul style="list-style-type: none"> Balanced or in surplus Country-specific MTO: maximal structural deficit of 0.5% of GDP (or at most 1% if debt-to-GDP ratio is below 60% and risks to sustainability are low)
Escape clauses	<ul style="list-style-type: none"> Severe economic downturn in euro area or EU as a whole Unusual event outside the control of the government with major financial impact Implementation of structural and/or pension reform (under strict conditions) 	<ul style="list-style-type: none"> Replicates reinforced SGP (without explicit reference to structural and/or pension reforms)
Convergence to budgetary objective	<ul style="list-style-type: none"> Assessed on the basis of the structural balance and primary expenditure rule Benchmark: annual improvement of structural balance of 0.5% of GDP (higher in economic good times and/or if debt-to-GDP ratio exceeds 60% or pronounced risks to sustainability of overall debt; might be lower in bad economic times) 	<ul style="list-style-type: none"> Rapid convergence to MTO (details to be proposed by the Commission) taking sustainability risks into consideration Evaluation of progress as in the revised SGP
Assessing compliance	<ul style="list-style-type: none"> Significant observed deviation (for a Member State that has not reached its MTO) in case of simultaneous breach of the two following criteria (or breach of one and limited compliance with the other): <ol style="list-style-type: none"> Structural deficit criterion: exceeding adjustment path to MTO by at least 0.5% in one or 0.25% on average in two consecutive years; Expenditure criterion: negative impact of expenditure developments (net of discretionary revenue measures) on adjustment path of government balance of at least 0.5% of GDP in one or cumulatively in two consecutive years. 	<ul style="list-style-type: none"> Assessment of "significant observed deviations from the MTO or the adjustment path towards it" follows the revised SGP Common principles on the role and independence of additional monitoring institutions proposed by the Commission
Correction mechanism	<ul style="list-style-type: none"> In case of a significant observed deviation from the adjustment path towards the MTO: warning by European Commission Council recommendation for the necessary policy measures on the basis of a Commission recommendation (deadline of not more than 5 months (3 months in particularly serious cases) for addressing the deviation) 	<ul style="list-style-type: none"> Shall be triggered automatically in the event of significant observed deviations from the MTO or its adjustment path (including obligation to implement measures to correct the deviations over a defined period of time) Implemented at the national level on the basis of common principles (nature, size and time-frame of the corrective action, also in the case of exceptional circumstances) as proposed by the Commission Correction should (according to FC) include the cumulated impact of past deviations on government debt dynamics
Enforcement	<ul style="list-style-type: none"> Commission can propose financial sanction (interest-bearing deposit of 0.2% of GDP) in case of no effective action taken Automatic approval (sanction) – unless Council rejects the Commission recommendation by qualified majority (only euro area Member States without country concerned) 	<ul style="list-style-type: none"> In addition to the reinforced SGP, financial sanctions can be imposed if the balanced budget rule and the correction mechanism are not properly implemented in national law despite earlier judgement by the European Court of Justice on non-compliance (imposed by the Court)

Source: based on ECB (2012b) - recently updated.

3.2 Effects on the corrective arm

The fiscal compact leads to more automaticity in the procedures of the corrective arm of the SGP following a breach of the deficit criterion by a euro area country. In this case, contracting parties whose currency is the euro commit to supporting the Commission's proposals or recommendations for Council decisions in the framework of an excessive deficit procedure, unless a qualified majority of them (without the Member State concerned) is opposed to such a decision (see Figure 16). The introduction of this voting commitment by euro area countries for important procedural steps, such as the opening of an excessive deficit procedure, the decision whether a euro area Member State has taken effective action, and a possible stepping-up of the excessive deficit procedure, increases the automaticity of procedures compared to the reinforced SGP. This implies, for instance, that if the Commission were to conclude after a euro area country breaches the deficit criterion that an excessive deficit exists and addresses a corresponding opinion to the Member State concerned and a proposal to the Council, the proposal will pass unless a qualified majority among the euro area members of the Council decides to oppose it.⁶

Fig. 16- Comparison of the corrective arm of the reinforced Stability and Growth Pact with the fiscal compact

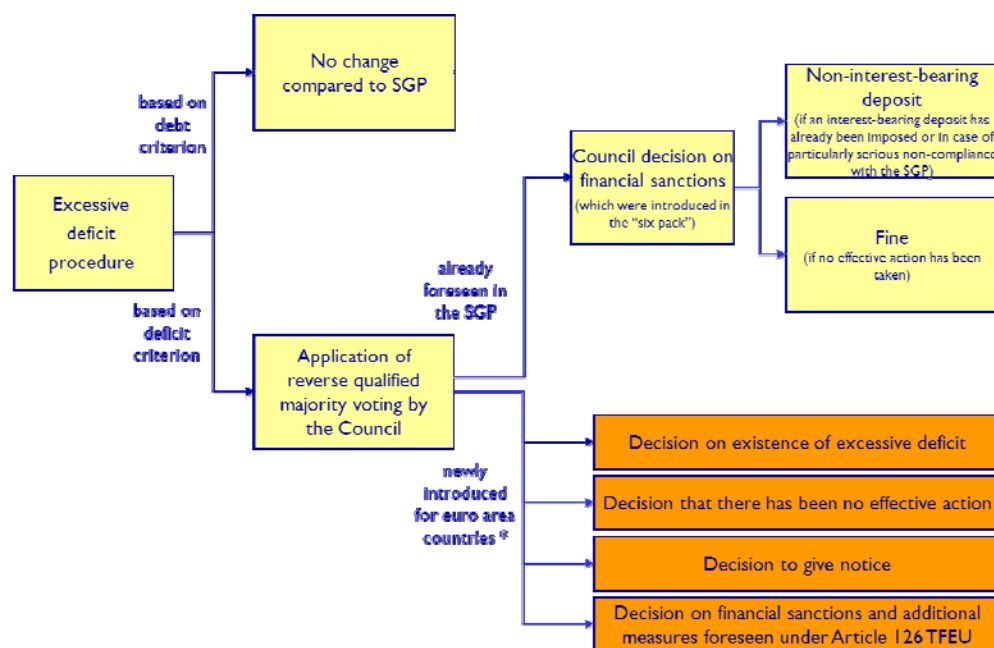

Notes: Under the reinforced SGP an excessive deficit procedure can be initiated on the basis of a breach of the deficit criterion and/or a breach of the debt criterion. The fiscal compact strengthens the

⁵ The updated code of conduct of the SGP (from 24 January 2012) foresees that significant deviations require at least a breach of one criterion and limited compliance with the other (see Table 2 in the code of conduct). This could mean that deviations of the structural budget balance from the MTO or the adjustment path towards it alone are not sufficient for a significant deviation if the country still complies with the expenditure criterion.

⁶ Note that since the entry into force of the Lisbon Treaty on 1 December 2009, only Member States whose currency is the euro have the right to vote in the Council concerning measures related to excessive deficits of euro area members.

decision-making procedure of the excessive deficit procedure following a breach of the deficit criterion by a euro area country, but not that in case of a breach of the debt criterion. In particular, the fiscal compact provides for the application of reverse qualified majority voting by the euro area countries on important steps in the excessive deficit procedure (marked in lighter blue), for which Article 126 of the Treaty demands qualified majority voting. This increases the automaticity of the excessive deficit procedure following a breach of the deficit criterion. If a Member State repeatedly fails to comply with a decision by the Council, the Council may apply additional measures under Article 126 of the Treaty. The Council may, for example, require the Member State concerned to publish additional information or to invite the European Investment Bank to reconsider its lending policy towards that Member State.

1) According to Article 7 TSCG, the contracting parties whose currency is the euro commit to supporting the proposals or recommendations submitted by the European Commission.

Source: ECB (2012b).

However, such reverse qualified majority voting will not be applied following a breach of the debt criterion by a euro area country. In these cases, the decision procedure as laid down in Article 126 of the Treaty will continue to apply, i.e. adoption by a qualified majority of euro area Member States, excluding the country concerned. Moreover, the excessive deficit procedure for non-euro area Member States is not affected at all.

3.3 Assessment: improvements of and remaining vulnerabilities of the EU fiscal framework after the fiscal compact?

Compared with the preventive arm of the SGP the fiscal compact offers four main improvements, provided they are strictly implemented and rigorously enforced.

First, from a legal perspective, it brings key elements of the SGP (EU secondary law) into an intergovernmental treaty, which requires the introduction of such key elements into the constitutions of contracting parties (or at least into legal acts of close-to-constitutional nature; see Table 1). Furthermore, the new conference of representatives of relevant committees of both the national parliaments and the European Parliament on the issues covered by the TSCG, including the fiscal compact, contributes to democratic accountability. These two aspects may increase national ownership, imply a firmer national anchoring of fiscal discipline and thereby create a stronger commitment to sound fiscal rules.

A second enhancement is that the fiscal compact should facilitate a more rapid convergence towards the country-specific MTOs, especially when due consideration is given to country-specific risks to fiscal sustainability, which in the aftermath of the financial crisis have risen substantially for many euro area countries. This requires that the Commission proposes ambitious and binding calendars of convergence, which go beyond the requirements of the reinforced SGP. A rapid convergence to MTOs can help to regain trust in the fiscal sustainability of EMU countries and restore the credibility of their fiscal policies. The

Commission is expected to publish such convergence calendars once the Stability and Convergence Programmes are updated in April 2013.

Third, the fiscal compact provides for an automatically triggered correction mechanism, which will be based on common principles to be proposed by the Commission. In this context, it is essential that the Commission elaborates [this is outdated, since the EC already published a Communication – better write that it does not meet our expectations] sufficiently well-specified, strict and binding requirements for the envisaged correction mechanism and its implementation in national law. Given the past experience of insufficiently declining or even rising government debt ratios, it is of utmost importance that, as foreseen in the fiscal compact, the mechanism fully corrects the cumulative impact on government debt of past observed deviations from the MTO (including those justified by the escape clause) in a timely manner. Moreover, the corrective measures to be implemented by contracting parties over a defined period of time must be triggered automatically. This should reduce the incentives and possibilities to postpone fiscal consolidation to later periods. Such an automatic correction mechanism should effectively amount to a ‘debt brake’ and contribute to preventing and correcting unsustainable public finances. In addition, it would constitute an important improvement compared to the preventive arm of the SGP, which aims at correcting significant deviations from the MTO or the adjustment path towards it, but does not foresee the correction of debt increases due to past budgetary slippages.⁷

The fourth enhancement offered by the fiscal compact is the possibility to call upon the European Court of Justice to verify the transposition of the balanced budget rule and the automatic correction mechanism into national law – including the possibility of financial sanctions to be imposed by the Court. The role of the Commission in this respect is limited to preparing a report that a contracting party may have introduced this balanced budget rule into its national law in a deficient way, or not at all, as only the other contracting parties can ask the Court to verify this transposition. In this context, it will be essential that the concrete procedures are clear and well-specified to ensure that a deficient introduction is brought before the Court. Monitoring actual observance of the balanced budget rule will not involve the Court. This responsibility is left to national institutions with a certain degree of independence, in addition, of course, to the whole budgetary surveillance mechanism of the SGP and other EU legislation (see also Chapter 4 on the ‘two-pack’).

With respect to the corrective arm, the higher degree of automaticity introduced by the fiscal compact for euro area countries that breach the deficit criterion appears to be a step in the

⁷ One could argue that for countries with government debt above 60% of GDP, the numerical benchmark of a reduction of the excess of their debt ratio over this reference value at an average rate of one-twentieth per year as a benchmark is one attempt to ensure the correction of past budgetary slippages.

right direction, since it reduces the leeway for political discretion in the framework of the excessive deficit procedure and makes a strict application of the rules and the application of sanctions more likely. This repairs at least partly an important shortcoming of the corrective arm of the SGP and strengthens the incentives for sound fiscal policies.

While some improvements of the fiscal compact are thus to be acknowledged, it cannot rectify the main shortcomings of the fiscal framework identified under part 2.4. There has been no progress with respect to the large number of exceptional situations that can be taken into account and weaken the application of the rules within the reinforced SGP. Automaticity has only been slightly improved in the corrective arm of the SGP. The effectiveness of the reinforced EU fiscal framework still depends heavily on a strict and rigorous application of the rules by the Commission and on a strict implementation of the commitments of the euro area contracting parties to vote in favour of the proposals and recommendations of the Commission in the context of the excessive deficit procedure following a breach of the deficit criterion unless a qualified majority of them is opposed. Furthermore, it remains crucial that the Commission uses its increased influence under the excessive deficit procedure by taking a rigorous approach when assessing fiscal deficits and avoids politically influenced decisions.

4. CLOSER MONITORING: THE ‘TWO-PACK’

4.1 Overview

Aware of the need to keep an even closer eye on whether euro area members continue to observe the agreed EU fiscal rules and of the necessity to move to more intrusive surveillance if they get into financial difficulties, the European Commission proposed two new EU regulations (known as the ‘two-pack’) to be adopted by the Council and the European Parliament (EP) under TFEU Article 136.1, which allows the adoption of specific measures in the euro area in order to ensure the proper functioning of EMU. The first regulation aims at strengthening budgetary surveillance and ensuring the correction of excessive deficits (henceforth: *budgetary regulation*). Hence, this regulation comprises elements which seek to enforce both the preventive and corrective arms of the SGP. The second regulation focuses on stepping-up economic and budgetary surveillance of euro area countries threatened with or already facing serious difficulties in respect of financial stability and/or fiscal sustainability that could spill over to other members, and/or that request or receive financial assistance (henceforth: *stability regulation*). As this regulation describes how to deal with troubled countries where earlier preventive and corrective actions were not effective, it falls under crisis management.

At the time of writing, the negotiations between the two co-legislators and the Commission on this ‘two-pack’ were still ongoing. Therefore, this chapter is based on the European Commission (2011a,b) proposals of November 2011, the EU Council (2012) general approach of February 2012 and the amendments put forward by the European Parliament (2012a,b) in June 2012. References to the views of the ECB (2012a) are taken from its legal opinion of March 2012.

4.2 Effects on the preventive arm

This section reviews the most important changes of the budgetary surveillance regulation affecting the preventive arm of the SGP.

(i) Euro area countries must have binding numerical fiscal rules in place

A first element of the Commission proposal is that it requires euro area countries to have in place binding numerical fiscal rules, preferably laid down in the constitution, that implement their MTOs. This would strengthen the legal status of a similar requirement in the Council Directive on national budgetary frameworks (Article 5) that was adopted as part of the ‘six-pack’ (see Chapter 2). As the Council was not in favour of explicitly demanding countries to have in place numerical fiscal rules, this aspect is unlikely to find its way in the final text.

(ii) Compliance with national fiscal rules needs to be monitored by an independent fiscal body

A second feature of the Commission proposal is that the implementation of national fiscal rules is to be monitored both *ex ante* and *ex post* by an independent fiscal council, i.e. a body endowed with functional autonomy *vis-à-vis* the fiscal authorities. The fiscal council should also produce [or endorse] the macroeconomic forecasts underlying the annual and medium-term budget plans. Also this provision is in line with similar requirements in the Council Directive on national budgetary frameworks (Articles 4 and 6). As requested under the fiscal compact, the European Commission (2012) published common principles on the role and independence of national monitoring institutions. Assuming that these common principles as outlined by the Commission find their way in the budgetary regulation, this could potentially lead to an important strengthening of the preventive arm of the SGP (as well as of the corrective arm).⁸

⁸ As shown by the experiences of Sweden, Netherlands and some other OECD countries with national fiscal councils, the effectiveness of a fiscal council crucially depends on how encompassing its role is in the budgetary process, whether its autonomy from the fiscal authorities within the scope of its mandate is credibly ensured and whether it enjoys strong political support. Compare: Hagemann, R. (2011): “How can fiscal councils strengthen fiscal performance?”, OECD Journal: Economic Studies, Vol. 2011/1. See as well the

(iii) Draft budget laws of euro area countries will be monitored by the Commission

Third, the Commission proposal extends EU budgetary surveillance to the draft budget laws of euro area countries which should facilitate an early assessment of fiscal discipline, including of potential spillover effects on other euro area members. Under a new common budgetary timeline Member States are required to publish in the spring their medium-term budgetary plans and submit in the autumn their government budget plans for the next year to the Commission (see Figure 17 below). The regulation also specifies the contents of the draft budget plans.⁹ The country-specific examination by the Commission and the discussion in the Eurogroup of the national and euro area budgetary situation and outlook before the draft budget laws are adopted by national parliaments by year-end create the possibility to check whether Member States abide by the EU fiscal rules and integrate the EU’s policy guidance. The Commission will [if necessary] adopt an opinion on the draft budgetary plans by end-November. Should the Commission detect ‘particularly serious non-compliance’ with the SGP, it should request [after consultation with the Member State concerned] a revised draft budget plan.

Fig. 17- Assessment of draft budgetary plans according to the budgetary regulation
(parts in brackets refer to open positions at time of writing)

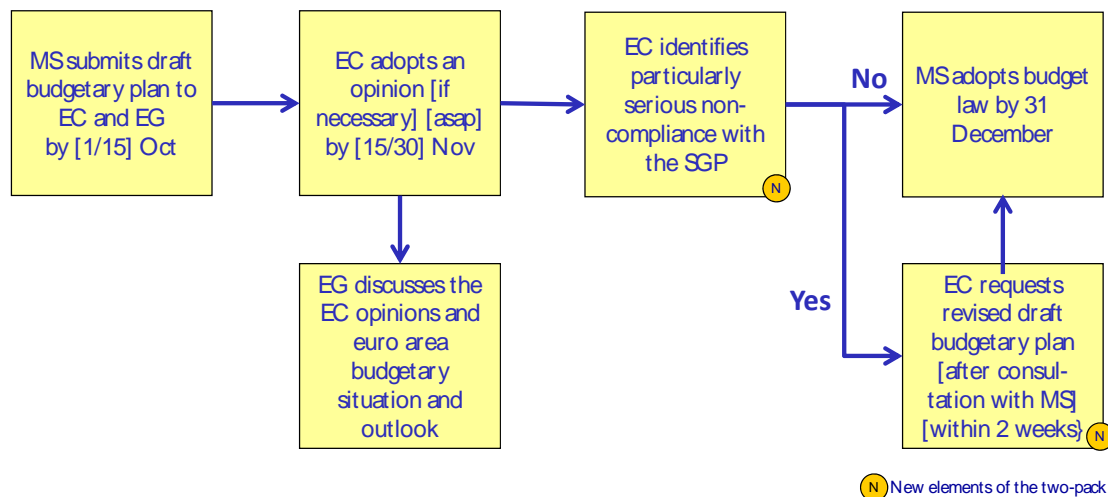

Source: Own illustration.

forthcoming ECB Monthly Bulletin article “The importance and effectiveness of national fiscal frameworks in the EU.”
⁹ Depending on the outcome of the negotiations, they will either be based on an agreed code of conduct or a delegated act of the Commission.

4.3 Effects on the corrective arm

This section reviews the most important changes of the budgetary surveillance regulation in respect of the corrective arm of the SGP.

(i) Commission will scrutinise the correction of an excessive deficit more closely

First, the Commission proposes that Member States subject to the EDP regularly report on the in-year execution of their budgets, the consolidation measures taken and the financial risks from contingent liabilities. On request they must also carry out an independent audit of the public accounts of the general government. Such closer scrutiny should secure that the correction of an excessive deficit stays on track. Should the Commission detect early signs of deviation from the fiscal consolidation targets and risks that the deadline for correcting the excessive deficit will not be met, it will address a public recommendation to the country concerned, which in that case must report back on the additional fiscal measures being taken to stay on course. The EP suggested to limit this requirement to cases in which the risk of deviations from target were not beyond the control of the country concerned.

(ii) Countries subject to an EDP must present an economic partnership programme

Second, as an element from the fiscal compact, the EP suggested adding that countries subject to an EDP must present an economic partnership programme outlining the structural reforms necessary to enhance competitiveness and long-term growth so as to ensure an effective and durable correction of the excessive deficit. The Council will adopt an opinion on these programmes and their implementation will be monitored by the Council and the Commission. This complements the report that EDP countries must present under the SGP to specify the budgetary actions taken in response to a Council recommendation to correct their excessive deficit. The focus on a sustained fiscal adjustment by asking the respective Member State to work also on the strength of its economy is intended to help to prevent recurrent situations of countries moving into an excessive budgetary position.

(iii) Commission will review the effectiveness of this regulation

Third, similar to the new regulation on financial sanctions that is part of the 'six-pack' (see Section 2.3), the Commission will publish by 14 December 2014 and every five years thereafter a report on the application of this budgetary regulation and where appropriate make a proposal for amendments. The purpose of this review clause is to evaluate the effectiveness of the budgetary regulation as well as the progress made in ensuring closer policy

coordination and sustained convergence of economic performance. The EP wished to add an assessment of the contribution to achieving the Union strategy for growth and jobs.

4.4 Crisis management

While the surveillance regulation of the “two-pack” is focusing on the application of the SGP in “normal times”, the stability regulation in effect complements the newly established euro area rescue funds (EFSF and ESM) which – in addition to possible other international lenders – may grant financial support to troubled countries that are assessed to be solvent. Its main goal is to ensure consistency between the EU multilateral surveillance framework and the conditionality attached to financial assistance granted by the EFSF and ESM (which are based on intergovernmental agreements) or other international lenders. In particular, the regulation establishes procedures for placing countries under enhanced surveillance, assessing government debt sustainability, deciding on macroeconomic adjustment programmes and the attendant in-programme and post-programme surveillance. The procedure is aimed at creating the economic and financial conditions that would relieve market tensions for the country concerned. Three key elements may be distinguished.

(i) Commission to enhance surveillance for countries in financial distress

First, the regulation seeks to ensure that EU economic and budgetary surveillance of a country under market stress is stepped up appreciably, in particular when it is receiving financial assistance. The Commission proposal gives itself the discretion to decide whether or not to place a country facing severe financial difficulties under enhanced surveillance. The EP introduced the possibility for the Council to repeal such a Commission decision by qualified majority and argued that this Commission decision must be made public. The ECB took the view that the necessity of closer monitoring in such a stressful situation is self-evident and it therefore suggested to empower the Council to request the Commission, if it is hesitant, to initiate or further pursue this enhanced surveillance. As part of this enhanced surveillance the Commission will conduct regular review missions in liaison with the ECB and the relevant European Supervisory Authorities (and where appropriate with the IMF) to verify progress in dealing with the situation. This replaces any on-site monitoring through surveillance missions provided for in the corrective part of the SGP (see discussion under Section 2.3).

(ii) Countries receiving financial assistance must prepare a macroeconomic adjustment programme

Second, the draft regulation specifies that a Member State requesting or receiving financial assistance must prepare a macroeconomic adjustment programme and that progress with its

implementation will be monitored by the Commission in liaison with the ECB and where relevant with the IMF. The basis for this is an assessment of the financing needs and the sustainability of government debt. The EP favoured to speed up the process by having the Commission approve the macroeconomic adjustment programme and just giving the Council the possibility to repeal this decision by qualified majority. Non-compliance with the policy requirements implies that the financial assistance might be suspended or even cancelled, whereby the EP urged to take account of reasons that are not under control of the country concerned.

(iii) Countries will be subject to post-programme surveillance

As regards post-programme surveillance the Commission proposal foresees continued monitoring as long as at least 75% of the financial assistance has not been repaid. Again, the EP favoured to speed up the process by having the Commission approve the duration of post-programme surveillance and just giving the Council the possibility to repeal this decision by qualified majority. In the Council's approach, however, this greater degree of automaticity was a bridge too far.

4.5 Assessment: Improvements by and and remaining vulnerabilities of the EU fiscal framework after the 'two-pack'?

The 'two-pack' offers a few promising legal elements that, if adopted, would help to remedy some of the weaknesses of the SGP identified above. In particular, the requirement that euro countries have in place numerical fiscal rules for which compliance is monitored by independent fiscal councils and the review of draft budgetary plans at the European level should allow for better prevention of fiscal policies going astray. Closer scrutiny of the correction of excessive deficits and economic partnership programmes should support a durable consolidation in line with targets. Also the ability to place a country under enhanced surveillance if risks to financial stability are evident is a welcome tool to bring countries back on the right fiscal track. As the new regulations give more powers to the Commission, their effectiveness will strongly depend on a forceful application by the Commission.

A particularly important element of the budgetary regulation under the 'two-pack' is that it empowers the Commission not only to issue an opinion on draft budgetary plans, but creates the opportunity to actually request a revised draft budgetary plan. This increases the possibility to sound the warning bell and increase political pressure even before measures are actually adopted. The ECB commented that as a matter of principle a draft budget law should always fully comply with the obligations under the SGP; if not, it would be a duty of the Commission as guardian of the Treaty and of the SGP to demand a revision. The formulation

that the Commission would only request a revision of the budget plan in case of ‘particularly serious non-compliance’ (a wording taken from the financial sanctions regulation associated with the SGP) [and only after consultation with the Member State] suggests a great reluctance on the part of the Commission to use its new enforcement powers. Apparently it is confident that the threat of being able to use this ‘nuclear option’ is already sufficient to deter the preparation of non-compliant draft budgets. From our perspective, however, this is not assured, even more so as there are no sanctions envisaged for a country that refuses to adjust its draft budget law. Only when an assessment must be made of whether to place a country in the excessive deficit procedure the lack of follow-up to the Commission’s opinion will be seen as an aggravating factor. Hence, this part of the legislation which on paper appears as a tiger, is unlikely to have the teeth to bite in practice.¹⁰

Also the opportunity for the Commission to ask a Member State during the execution of a budget to take additional measures to stay on track with meeting the deadline for the correction of an excessive deficit should help to avoid observed deviations from target and anticipate a necessary correction. The ECB moreover advocated that the Eurogroup discuss the adequacy of the additional measures, so as to increase peer pressure at an early stage. The possibility to conduct a review of the effectiveness of the budgetary legislation offers the chance to correct some of the weaker elements and to integrate as intended further aspects of the fiscal compact in EU law.

The EP demanded to include in the ‘two-pack’ that the Commission should present a possible roadmap towards the common issuance of euro area sovereign debt instruments and examine the feasibility of introducing a European public debt redemption fund, combined with strict rules on fiscal adjustment. However, this proposal is unlikely to be acceptable to many Member States. Indeed, fiscal risk sharing could only take place after an appropriate degree of fiscal sovereignty has been transferred to the euro area level.¹¹ Moreover, a legal assessment by the European Court of Justice (2012) suggests that public debt mutualisation is incompatible with the Treaty’s ‘no-bail out’ rule (TFEU Article 125). The EP request that the Commission should evaluate the possibility of creating a European authority responsible for managing and coordinating public debt issuance and assessing the sustainability of government debt is equally likely to be rejected by the Council.

¹⁰ To give the tiger teeth and to make it bite, if needed, Schuknecht et al. (2011) propose that planned national budget deficits, if they exceed the 3% of GDP reference value, must be formally approved unanimously by the other euro area governments. Where the planned deficits exceed a country’s MTO, they would have to be approved by qualified majority. Most likely, these changes would go beyond the limits of the Treaty.

¹¹ See also the text on budgetary integration in Van Rompuy (2012).

Our assessment of the *stability regulation* is focused on how effective the legal provisions are likely to be in achieving the objective of reducing market pressure on a country risking financial instability by ensuring that the necessary policy adjustments are undertaken.

The stability regulation remains unclear on how strong the conditionality will be for countries that just apply for precautionary credit lines, loans for the recapitalisation of financial institutions or for possible support instruments that may be added later to the EFSF/ESM toolbox. As pointed out by the ECB, there is a case for monitoring whether countries with access to precautionary assistance fulfil the eligibility criteria on an ongoing basis and maintain sustainable public finances. The EP moreover suggested to restrict the scope of macroeconomic adjustment programmes by protecting fundamental public spending on education and health care and asking to respect wage bargaining institutions. Overall, this indicates that the policy conditions associated with financial support instruments may turn out less ambitious than warranted. This is unfortunate, since for programme countries the ordinary EU surveillance under the European Semester, SGP and MIP and will be suspended to avoid a duplication of procedures and overburdening of the countries concerned.¹² As argued in the Council's approach, the Commission may even recommend to reduce or cancel financial sanctions under the preventive and corrective arms of the SGP on the grounds of exceptional economic circumstances. This must be regarded as a potential weakening of the EU multilateral surveillance framework.

Finally, it should be noted that the stability regulation foresees that non-compliance with conditionality needs to be decided based on a qualified majority in the Council. This could reduce the ability of the Council to enforce conditionality in existing programmes further, as a blocking minority could effectively prevent the diagnosis of non-compliance and hence the discontinuation of financial support.

5. OVERALL EVALUATION

The six-pack, the 'two-pack' and the fiscal compact contain the most far-reaching reforms of the fiscal governance framework since the introduction of the single currency. But are they far-reaching enough to qualify as a quantum leap, that rectifies the central vulnerabilities and makes the fiscal framework fully commensurate to the requirements of the single currency?

¹² As they are not explicitly mentioned, only the rules of the fiscal compact would presumably still apply.

To evaluate this question we first need to define major elements of a quantum leap in the “Maastricht World” (with ultimate national responsibility for fiscal policies).¹³ These elements can be applied to assess the preventive as well as the corrective elements of the reinforced EU fiscal governance framework and include:¹⁴

- a) strict and well-defined numerical rules:
 - (i) implement strict and ambitious deadlines,
 - (ii) eliminate escape clauses,
- b) early intervention in draft budget plans and consolidation measures that do not abide by the obligations under the SGP,
- c) ensure an automatic correction of past cumulated slippages (avoid ‘moving deficit targets’),
- d) a transformation to a fairly automatic system, limiting the room for political discretion in case of deviation from fiscal targets on all levels (including implementation of sanctions),
- e) enable timely, credible and ‘biting’ sanctions in case of non-compliance with fiscal rules,
- f) strong national anchoring, leaving national governments no other option than to pass compliant budgets.

How do the recent reforms of EU fiscal governance compare against these requirements? Figure 19 gives an overview of the impact of the different reform packages.

Fig. 19 – Reform of fiscal governance - a quantum leap?

¹³ In their seminal contribution, Kopits and Symansky single out a larger number of optimal features of fiscal rules, namely: fiscal rules need to be well-defined, transparent, adequate, consistent with other rules, simple, flexible to accommodate large exogenous shocks, enforceable and they need to be supported by efficient policy actions (see Kopits and Symansky (1998):“Fiscal policy rules”, IMF Occasional Paper 162). In this paper we restrict our perspective to the features, which have proven to be critical in the past.

¹⁴ See as well Schuknecht et al. (2011).

Kopits/ Syman ski	Important aspects	Reinforcement of the EU fiscal governance framework and remaining reform needs					
		Preventive approach			Corrective approach		
Well defined	Tightness of deadlines to convergence (versus possibilities to postpone adjustment)	6P: No general change 2P: - FC: "Rapid convergence" still to be defined	(+)	xx	6P: earlier sanctions 2P: - FC: -	+	xx
	Possibility to circumvent procedures (escape clauses)	6P: add. escape clauses 2P: - FC: "Rapid convergence" still to be defined	-/+	xxx	6P: - 2P: - FC: -	-	xxx
	Early intervention possibilities in draft budget plans	6P: opinion on SCP 2P: Request of revised budgets FC: -	++	xx	6P: - 2P: - FC: -	-	x
	Correction of past deviations/incentive to postpone consolidation into the future	6P: - 2P: - FC: Barely any change through ACM	-	xxx	6P: - 2P: - FC: -	-	xx
Enforceable	Degree of automaticity of procedures (versus political discretion)	6P: increased automaticity 2P: - FC: increased automaticity	++	xx	6P: increased automaticity 2P: - FC: increased automaticity	++	xx
	Enforcement of implementation	6P: sanctions 2P: - FC: ECJ procedure	++	xx	6P: sanctions 2P: - FC: -	+	xx
Consistent	National anchoring	6P: NFF 2P: - FC: national law	++	x	6P: NFF 2P: - FC: -	-	x

Legend: "+/++/+++" slight/substantial/large improvement; "-" no change; "()" conditional on implementation; "x/xx/xxx" further/slight/substantial/large improvement needed

Source: Own illustration.

We find that the strongest improvements have been achieved with respect to automaticity of the procedures in the preventive as well as in the corrective arm. Here especially the introduction of reversed qualified majority voting in the six-pack, which was reinforced by the fiscal compact, is promising. The Commission's early examination of draft budgetary plans before their formal adoption by national parliaments, and its closer monitoring of risks that a country may not meet the deadline for correcting an excessive deficit, once agreed, will offer additional safeguards for securing sound public finances. An important potential 'sanction' in this respect is the possibility for the Commission to request a revised draft budgetary plan from a euro area country if it identifies particularly serious non-compliance with the obligations under the SGP. Moreover, the additional financial sanctions – introduced via the 'six-pack' in the preventive and the corrective arm of the SGP – as well as the new role of the European Court of Justice for verifying the transposition of the balanced budget rule of the fiscal compact at the national level are important. Finally, there has been a clear strengthening of the national anchoring by the fiscal compact (which effectively transposes the preventive arm of the SGP into national law) and the Council Directive for national

budgetary frameworks (which we did not evaluate in detail).¹⁵ The new requirement to have in place independent national fiscal councils or monitoring institutions should also help to strengthen budgetary discipline.

Despite these improvements, central weaknesses remain.

- 1) **A lack of sufficient automaticity in the procedures of the SGP in case of non-compliance with the rules:** the Council continues to have substantial room for discretion under the reinforced SGP.¹⁶

This room for discretion is especially critical in case many Member States do not comply to the rules. “Sinners who judge sinners” have no interest in a strict application of the rules. Looking back, this can contribute to explaining why for example sanctions have never been applied under the SGP. Figure 20 reveals that in every year since the beginning of EU, a majority of countries has not complied with their MTO (within the preventive arm of the SGP). In such a constellation, peer pressure is unlikely to work. In recent years – and the near future based on the autumn 2012 forecast of the European Commission, only one or two countries are complying to their MTO.

Fig. 20 - Past compliance with the preventive arm of the SGP (based on ex post data)¹⁷

	Structural net lending(+)/borrowing(-) (until 2002 - only cyclically adjusted data)																			
	MTO	1995	1996	1997	1998	1999	2000	2001	2002	2003	2004	2005	2006	2007	2008	2009	2010	2011	2012	2013
Belgium	0.50	-4.3	-3.4	-2.3	-0.8	-1.0	-1.0	0.0	-0.1	-1.1	-1.4	-0.9	-1.2	-1.2	-2.0	-3.9	-3.3	-3.4	-2.7	-2.7
Germany	-0.50	-9.5	-2.9	-2.4	-2.2	-1.6	0.4	-3.8	-3.8	-3.2	-2.9	-2.2	-1.7	-0.9	-0.9	-0.9	-2.3	-0.7	0.2	0.3
Estonia	>0			2.8	-0.6	-2.2	-0.5	-0.7	-0.5	0.4	1.5	0.1	-1.1	-1.5	-4.5	-1.1	-1.2	-0.7	-0.4	-0.4
Ireland	-0.50	-2.0	-0.5	0.0	1.4	1.2	2.8	-0.5	-1.2	0.3	1.6	1.7	2.3	-1.5	-7.5	-10.1	-9.4	-7.9	-7.9	-7.5
Greece	BB	-9.1	-6.6	-6.1	-4.1	-3.3	-4.0	-4.6	-4.3	-5.6	-7.8	-5.3	-7.2	-7.7	-9.6	-14.7	-8.7	-5.4	-1.5	0.7
Spain	>0	-6.0	-4.4	-3.4	-3.0	-1.8	-2.0	-1.6	-0.9	-0.8	0.3	0.8	1.6	1.0	-4.4	-8.7	-7.6	-7.5	-6.3	-4.0
France	BB	-4.9	-3.1	-2.5	-2.6	-2.4	-2.9	-3.1	-4.3	-4.6	-4.6	-4.5	-3.9	-4.4	-4.1	-6.1	-5.7	-4.5	-3.4	-2.0
Italy	BB	-7.7	-7.1	-3.0	-2.8	-2.1	-1.8	-4.3	-3.8	-5.4	-5.1	-5.4	-4.1	-3.3	-3.7	-4.3	-3.7	-3.7	-1.4	-0.4
Cyprus	BB			-4.1	-3.7	-4.4	-3.0	-3.3	-4.9	-8.0	-4.9	-2.9	-1.1	2.6	-0.6	-6.2	-5.3	-5.9	-4.6	-4.8
Luxembourg	0.50	3.2	2.8	4.6	3.4	2.3	3.7	4.8	1.0	0.6	-0.9	-0.2	0.6	1.6	2.5	0.9	0.0	0.2	-1.1	-0.9
Malta	BB	-3.5	-7.9	-7.8	-10.2	-7.9	-7.5	-6.7	-6.6	-6.2	-5.9	-3.8	-2.8	-2.8	-5.4	-3.7	-4.6	-3.5	-3.5	-3.2
Netherlands	-0.50	-3.8	-1.4	-1.2	-1.1	-0.5	0.7	-1.1	-1.7	-1.8	-0.9	0.5	0.4	-1.1	-0.7	-4.1	-3.9	-3.4	-2.2	-1.1
Austria	-0.45	-5.4	-3.7	-1.4	-2.5	-2.8	-2.6	-0.3	-0.7	-0.9	-0.7	-1.3	-1.8	-1.9	-1.9	-2.8	-3.4	-2.3	-2.6	-2.1
Portugal	-0.50	-4.8	-4.6	-4.0	-4.8	-4.3	-4.8	-6.1	-4.1	-5.6	-5.7	-6.0	-4.4	-3.7	-4.4	-8.5	-8.4	-6.2	-4.1	-2.5
Slovenia	BB						-4.3	-4.0	-2.5	-2.6	-2.5	-2.0	-2.8	-2.9	-4.8	-4.3	-4.6	-4.7	-2.8	-2.0
Slovakia	BB				-5.7	-6.9	-11.4	-5.8	-7.8	-2.1	-2.1	-1.8	-3.3	-3.6	-4.2	-7.5	-7.4	-5.4	-5.1	-3.2
Finland	0.50	-4.4	-2.2	-1.8	0.6	0.8	5.5	4.3	4.2	3.3	2.5	2.8	3.0	2.4	2.4	1.0	-0.4	0.3	-0.6	-0.1
Euro area		-1.2	-2.9	-3.1	-3.3	-3.0	-2.6	-2.1	-2.0	-2.9	-4.6	-4.4	-3.5	-2.2	-1.3	-1.5				
non-compliant						7	6	7	9	8	8	7	6	9	12	13	14	15	16	15
% non-compliant						64%	55%	58%	75%	67%	67%	58%	50%	69%	80%	81%	88%	88%	94%	88%
																				EMU membership in bold

Note: in red: observations of non-compliance; non-compliant= number of EMU countries not complying to the benchmark (second row: in % of EMU members)¹⁸

Source: Own illustration.

¹⁵ See as well the forthcoming ECB Monthly Bulletin Article “The importance and effectiveness of national fiscal frameworks in the EU.”

¹⁶ For example, the Council still has – on the basis of an overall assessment – to decide by qualified majority that an excessive deficit based on the debt criterion does exist to start an EDP.

¹⁷ An analysis based on real-time data would be more accurate in this context and is currently pursued by the authors.

¹⁸ Currently we are pursuing this analysis taking voting weights and voting rules (under the old and the reinforced SGP) into account.

With respect to the corrective arm, the compliance with the 3% deficit criterion is somewhat better. Only in around 50% of the years between 1999 and 2014, a majority of countries has not been complying with the deficit criterion. Nonetheless, non-compliance still dominates – especially in recent years. Furthermore, some countries (notably Greece and Portugal) have not complied to the 3% criterion in a singly year since they joined EMU and they have never faced any financial sanctions.

Fig. 21 - Past compliance with the deficit criterion under the corrective arm of the SGP (based on ex post data)¹⁹

	Net lending(+)/borrowing(-)																				
	1995	1996	1997	1998	1999	2000	2001	2002	2003	2004	2005	2006	2007	2008	2009	2010	2011	2012	2013	2014	
Belgium	-4.5	-4.0	-2.2	-0.9	-0.6	0.0	0.4	-0.1	-0.1	-0.1	-2.5	0.4	-0.1	-1.0	-5.5	-3.8	-3.7	-3.0	-3.4	-3.5	
Germany	-9.5	-3.4	-2.8	-2.3	-1.6	1.1	-3.1	-3.8	-4.2	-3.8	-3.3	-1.6	0.2	-0.1	-3.1	-4.1	-0.8	-0.2	-0.2	0.0	
Estonia	1.1	-0.3	2.2	-0.7	-3.5	-0.2	-0.1	0.3	1.7	1.6	1.6	2.5	2.4	-2.9	-2.0	0.2	1.1	-1.1	-0.5	0.3	
Ireland	-2.2	-0.3	1.0	2.2	2.6	4.7	0.9	-0.4	0.4	1.4	1.7	2.9	0.1	-7.4	-13.9	-30.9	-13.4	-8.4	-7.5	-5.0	
Greece	-9.1	-6.7	-5.9	-3.9	-3.1	-3.7	-4.5	-4.8	-5.7	-7.6	-5.5	-5.7	-6.5	-9.8	-15.6	-10.7	-9.4	-6.8	-5.5	-4.6	
Spain	-7.2	-5.5	-4.0	-3.0	-1.2	-0.9	-0.5	-0.2	-0.3	-0.1	1.3	2.4	1.9	-4.5	-11.2	-9.7	-9.4	-8.0	-6.0	-6.4	
France	-5.5	-4.0	-3.3	-2.6	-1.8	-1.5	-1.6	-3.3	-4.1	-3.6	-2.9	-2.3	-2.7	-3.3	-7.5	-7.1	-5.2	-4.5	-3.5	-3.5	
Italy	-7.4	-7.0	-2.7	-2.7	-1.9	-0.8	-3.1	-3.1	-3.6	-3.5	-4.4	-3.4	-1.6	-2.7	-5.4	-4.5	-3.9	-2.9	-2.1	-2.1	
Cyprus	-0.9	-3.2	-5.1	-4.2	-4.3	-2.3	-2.2	-4.4	-6.6	-4.1	-2.4	-1.2	3.5	0.9	-6.1	-5.3	-6.3	-5.3	-5.7	-6.0	
Luxembourg	2.4	1.2	3.7	3.4	3.4	6.0	6.1	2.1	0.5	-1.1	0.0	1.4	3.7	3.2	-0.8	-0.8	-0.3	-1.9	-1.7	-1.8	
Malta	-3.8	-8.2	-7.7	-10.0	-7.2	-5.8	-6.4	-5.8	-9.2	-4.7	-2.9	-2.8	-2.3	-4.6	-3.9	-3.6	-2.7	-2.6	-2.9	-2.6	
Netherlands	-4.3	-1.9	-1.2	-0.9	0.4	2.0	-0.2	-2.1	-3.1	-1.7	-0.3	0.5	0.2	0.5	-5.6	-5.1	-4.5	-3.7	-2.9	-3.2	
Austria	-5.8	-4.0	-1.8	-2.4	-2.3	-1.7	0.0	-0.7	-1.5	-4.4	-1.7	-1.5	-0.9	-0.9	-4.1	-4.5	-2.5	-3.2	-2.7	-1.9	
Portugal	-5.4	-4.9	-3.7	-3.9	-3.1	-3.3	-4.8	-3.4	-3.7	-4.0	-6.5	-4.6	-3.1	-3.6	-10.2	-9.8	-4.4	-5.0	-4.5	-2.5	
Slovenia	-8.3	-1.1	-2.3	-2.4	-3.0	-3.7	-4.0	-2.4	-2.7	-2.3	-1.5	-1.4	0.0	-1.9	-6.0	-5.7	-6.4	-4.4	-3.9	-4.1	
Slovakia	-3.4	-9.9	-6.3	-5.3	-7.4	-12.3	-6.5	-8.2	-2.8	-2.4	-2.8	-3.2	-1.8	-2.1	-8.0	-7.7	-4.9	-4.9	-3.2	-3.1	
Finland	-6.1	-3.4	-1.3	1.7	1.7	7.0	5.1	4.2	2.6	2.5	2.9	4.2	5.3	4.4	-2.5	-2.5	-0.6	-1.8	-1.2	-1.0	
Euro area	-7.2	-4.3	-2.8	-2.3	-1.5	-0.1	-2.0	-2.7	-3.1	-2.9	-2.5	-1.4	-0.7	-2.1	-6.3	-6.2	-4.1	-3.3	-2.6	-2.5	
non-compliant					1	1	4	5	6	6	4	4	3	7	14	14	11	11	10	11	
% non-compliant					9%	9%	33%	42%	50%	50%	33%	33%	23%	47%	88%	88%	65%	65%	59%	65%	
																					EMU membership in bold

Note: in red: observations of non-compliance; non-compliant= number of EMU countries not complying to the benchmark (second row: in % of EMU members)²⁰

Source: Own illustration.

2) The effectiveness of the reinforced fiscal framework depends heavily on a strict and rigorous application of the rules by the Commission.²¹ If the Commission yields to political pressure, the rules are unlikely to bite. First experiences under the new European Semester have been disappointing.

The importance of a strict implementation of the rules can be demonstrated based on the EDP (see Figure 22). Before the recent reforms, strict application of the EDP under the corrective arm and compliance by the Member State would have led to a correction of the excessive deficit two years after it occurred. However, if the Commission and the Council

¹⁹ An analysis based on real-time data would be more accurate in this context and is currently pursued by the authors.

²⁰ Currently we are pursuing this analysis taking voting weights and procedures (under the old and the reinforced SGP) into account.

²¹ The Commission plays a decisive role in the assessment of the existence of an excessive deficit (taking into account a large number of relevant – in most cases mitigating – factors), of whether Member States have taken effective action to correct an excessive deficit or if the deadline for correcting the excessive deficit should be extended. Another example is that the Commission can give a recommendation to the Council to reduce or cancel the new financial sanctions, either on grounds of exceptional economic circumstances or following a request by the euro area Member State concerned.

applied the EDP only in a lax way, the excessive deficit would have been corrected only seven years after it occurred. Under the new framework, the scenario for a rigorous application is unchanged. With respect to the lax implementation scenario, the most important reform element is that the revised EDP foresees a financial sanction in case the Council diagnoses “no effective action”. As the Council decides on this fine with reversed qualified majority (see Section 2.3), it is relatively likely to be implemented. Therefore, the new procedures reduce the time until an excessive deficit is likely to be eliminated under a lax implementation of the EDP from seven to five years. However, this is still a relatively long time span – especially as average deficits above the 3% threshold for a longer time are likely to push up the debt ratio.

Fig. 22- Strict versus lax implementation of the EDP: possible steps under the EDP before sanctions are applied

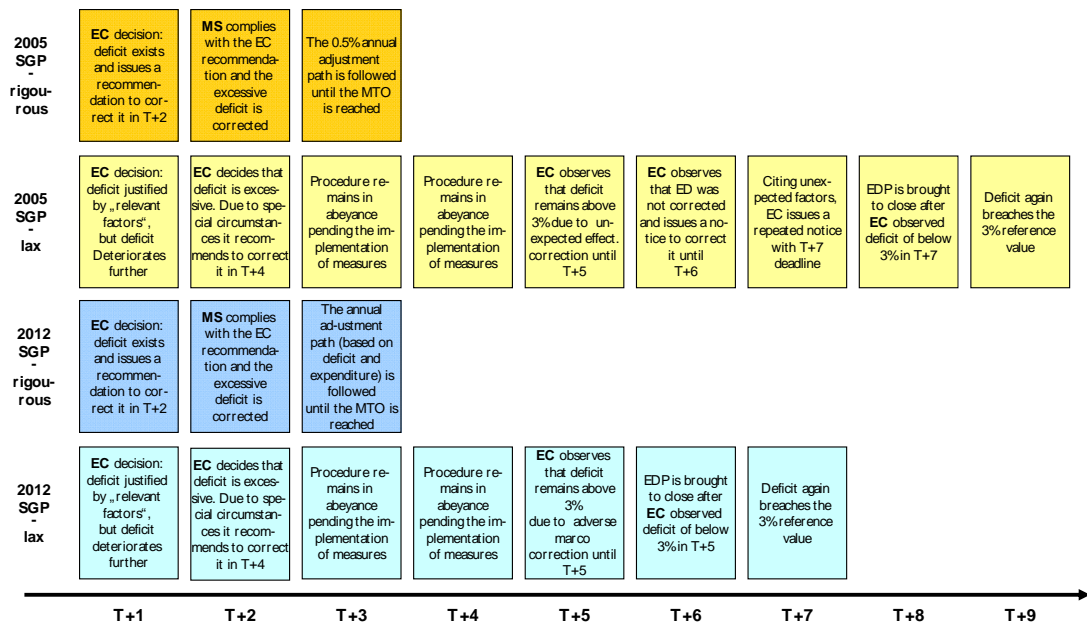

Source: Analysis of 2005 SGP as in Morris, Ongena and Schuknecht (2006): The reform and implementation of the Stability and Growth Pact. ECB Occasional Paper, 47, p. 24. 2012 – own illustration.

- 3) **The framework does not effectively prevent upward debt trajectories, treating past deficits above the numerical benchmarks and past slippages as bygones.** The preventive and the corrective arm of the SGP do not require the correction of past deviations from numerical benchmarks, but only compliance with fiscal adjustment paths to be defined after deviations occurred. In effect, average deficits well above the numerical targets, which can lead to upward debt trajectories, are implicitly ‘tolerated’ by the framework.

This can be nicely illustrated based on the deviations of fiscal plans from fiscal outcomes (see Figure 23). Based on the European fiscal framework, the plans for consolidation

included in the stability programmes proved – e.g. for the euro area average – to largely comply with the requirements from the SGP (e.g. an continuous improvement by annually 0.5% of GDP in structural terms) . However, fiscal outcomes fell on average substantially short of the fiscal plans and the commitments remained moving targets, while the missing correction of past slippages contributed to rising debt ratios.

Fig. 23: Fiscal plans versus outcomes in the euro area average

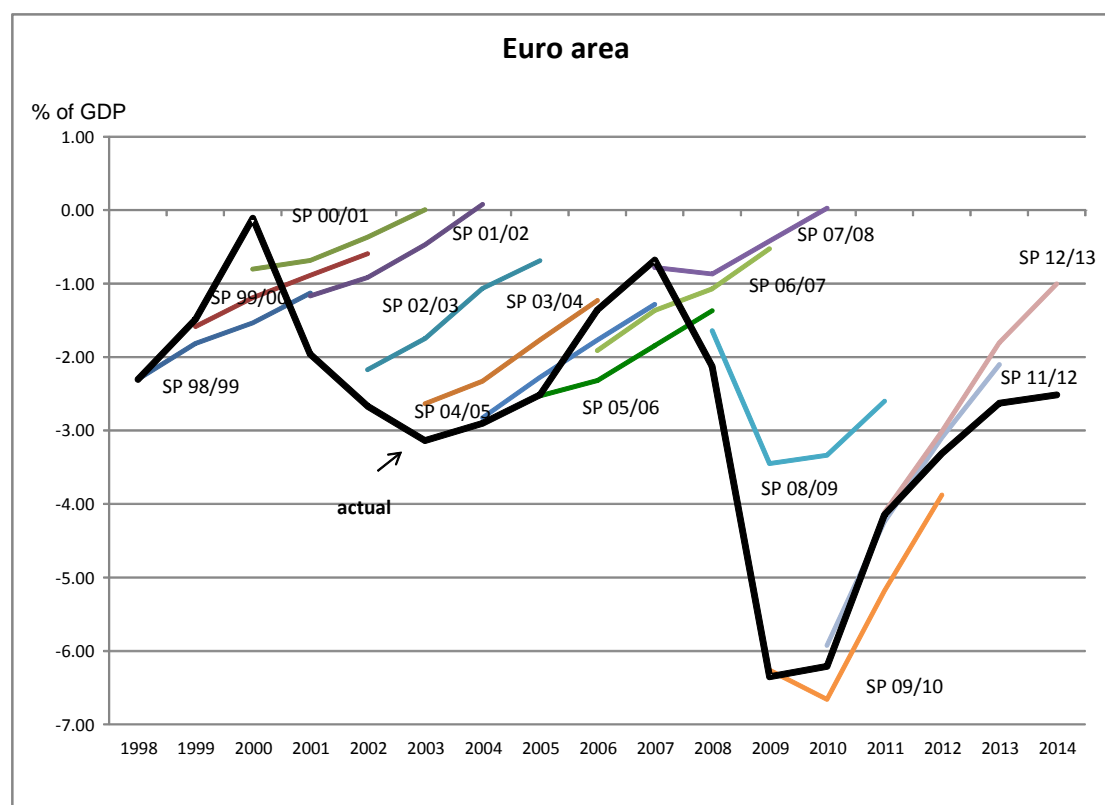

Source: Own illustration.

- 4) The **debt criterion in its current form is unlikely to prevent upward debt trajectories**: It is defined in terms of the debt ratio and asymmetric by requiring high consolidation especially in times of low economic growth (when consolidation is politically hard to implement), while it cannot ensure that good times (with high GDP growth) are not wasted. Furthermore, implementation is very complex (see appendix C for illustrations) and is subject to the general weaknesses of the SGP framework (discussed under point 1). This is even more crucial, as the fiscal compact foresees reverse qualified majority voting only for EDPs under the deficit, but not under the debt criterion (see Figure 16).

Past compliance with the debt criterion does not foster optimism with respect to a strict application of the new numerical benchmark within the SGP. Between 1999 and 2014 a

majority of countries has not complied to the debt criterion in all but three years. In particular, at the current juncture all but five relatively small countries are not complying with the debt criterion and average debt levels are high (Figure 24). This makes effective peers pressure to comply with the debt criterion unlikely.

Fig. 24 – Past compliance with the debt criterion under the corrective arm of the SGP (based on ex post data) ²²

	Gross debt																			
	1995	1996	1997	1998	1999	2000	2001	2002	2003	2004	2005	2006	2007	2008	2009	2010	2011	2012	2013	2014
Belgium	130.2	127.2	122.5	117.2	113.6	107.8	106.5	103.4	98.4	94.0	92.0	88.0	84.0	89.2	95.7	95.5	97.8	99.9	100.5	101.0
Germany	55.6	58.5	59.8	60.5	61.3	60.2	59.1	60.7	64.4	66.2	68.5	68.0	65.2	66.8	74.5	82.5	80.5	81.7	80.8	78.4
Estonia	8.2	7.6	7.0	6.0	6.5	5.1	4.8	5.7	5.6	5.0	4.6	4.4	3.7	4.5	7.2	6.7	6.1	10.5	11.9	11.2
Ireland	80.1	72.3	63.5	53.0	47.0	35.1	35.2	32.0	30.7	29.5	27.3	24.6	25.0	44.5	64.9	92.2	106.4	117.6	122.5	119.2
Greece	97.9	100.3	97.5	95.4	94.9	104.4	104.7	102.6	98.3	99.8	101.2	107.5	107.2	112.9	129.7	148.3	170.6	176.7	188.4	188.9
Spain	63.3	67.5	66.2	64.2	62.4	59.4	55.6	52.6	48.8	46.3	43.2	39.7	36.3	40.2	53.9	61.5	69.3	86.1	92.7	97.1
France	55.4	58.0	59.4	59.5	58.9	57.4	56.9	59.0	63.2	65.0	66.7	64.0	64.2	68.2	79.2	82.3	86.0	90.0	92.7	93.8
Italy	120.9	120.2	117.4	114.2	113.0	108.5	108.2	105.1	103.9	103.4	105.7	106.3	103.3	106.1	116.4	119.2	120.7	126.5	127.6	126.5
Cyprus	51.8	53.1	57.4	59.2	59.3	59.6	61.2	65.1	69.7	70.9	69.4	64.7	58.8	48.9	58.5	61.3	71.1	89.7	96.7	102.7
Luxembourg	7.4	7.4	7.4	7.1	6.4	6.2	6.3	6.3	6.1	6.3	6.1	6.7	6.7	14.4	15.3	19.2	18.3	21.3	23.6	26.9
Malta	35.3	40.1	48.4	53.4	57.1	54.9	60.5	59.1	67.6	71.7	69.7	64.0	61.9	62.0	67.6	68.3	70.9	72.3	73.0	72.7
Netherlands	76.1	74.1	68.2	65.7	61.1	53.8	50.7	50.5	52.0	52.4	51.8	47.4	45.3	58.5	60.8	63.1	65.5	68.8	69.3	70.3
Austria	68.2	68.1	64.1	64.4	66.8	66.2	66.8	66.2	65.3	64.7	64.2	62.3	60.2	63.8	69.2	72.0	72.4	74.6	75.9	75.1
Portugal	59.2	58.2	55.5	51.8	51.4	50.7	53.8	56.8	59.4	61.9	67.7	69.4	68.4	71.7	83.2	93.5	108.1	119.1	123.5	123.5
Slovenia	18.6	21.9	22.4	23.1	24.1	26.3	26.5	27.8	27.2	27.3	26.7	26.4	23.1	22.0	35.0	38.6	46.9	54.0	59.0	62.3
Slovakia	22.1	31.1	33.7	34.5	47.8	50.3	48.9	43.4	42.4	41.5	34.2	30.5	29.6	27.9	35.6	41.0	43.3	51.7	54.3	55.9
Finland	56.6	57.0	53.9	48.4	45.7	43.8	42.5	41.5	44.5	44.4	41.7	39.6	35.2	33.9	43.5	48.6	49.0	53.1	54.7	55.0
Euro area	72.0	73.7	73.2	72.9	71.7	69.2	68.2	68.1	69.2	69.6	70.3	68.7	66.4	70.2	80.0	85.6	88.1	92.9	94.5	94.3
non-compliant					6	4	4	5	6	7	7	7	7	8	10	12	12	12	12	14
% non-compliant					55%	36%	33%	42%	50%	58%	58%	58%	54%	53%	63%	75%	71%	71%	71%	82%

EMU membership in bold

Note: non-compliant= number of EMU countries not complying to the benchmark (second row: in % of EMU members)²³

Source: Own illustration.

- 5) The **early examination of draft budgetary plans and the possibility to request a revision** and the new focus on risks that consolidation measures may not be sufficient to correct an excessive deficit by the agreed deadline **do not allow to overrule national sovereignty as a preventive measure**. Hence, the prevention of observed significant deviations from the EU fiscal rules ultimately depends on the effectiveness of independent national monitoring institutions in advising governments on sound fiscal policies and on the willingness of national governments to abide by the EU fiscal rules,
- 6) Furthermore the **framework continues to lack instruments for situations in which a country's fiscal policy, despite existing surveillance, enforcement and correction mechanisms on the national level and the European level, continues to go harmfully astray**. Ex-post sanctions lack credibility, especially when a country already faces risks of financial instability associated with an unsustainable fiscal position. The possibility to place a euro area country in that situation under enhanced surveillance or even a macroeconomic adjustment programme can only be seen as a crisis management tool that

²² An analysis based on real-time data would be more accurate in this context and is currently pursued by the authors.

²³ Currently we are pursuing this analysis taking voting weights and voting rules (under the old and the reinforced SGP) into account.

enables a belated correction. Therefore, there is a need to reflect on more binding constraints on national fiscal policies which could effectively prevent budgetary imbalances from building up in the first place.

Against this background, we conclude that the recent reforms of EU fiscal governance constitute important improvements but no quantum shift. Therefore the **review clauses** that have been entered in some of the new regulations should be used to the fullest extent for increasing the level of ambition towards securing fiscal discipline. In the longer term, even a **qualitative move towards a fiscal union is necessary** to ensure sound fiscal policies and make the fiscal framework fully commensurate to the requirements of the single currency (see also Van Rompuy, 2012). **At the core of such a move is the further sharing of fiscal sovereignty**, accompanied where necessary by a change in the Treaty. This means that the ultimate authority to decide on fiscal policy lies no longer at the national, but at the European level. This does not mean that the European level needs to receive the power to determine national fiscal policies in detail. It seems sufficient that the European level has ex ante the power to effectively enforce compliance with the existing numerical benchmarks (as e.g. the balanced budget requirement) enshrined in the fiscal rules (and not only to monitor compliance based on fiscal adjustments paths after deviations have occurred). To this end, two options could be used to achieve the needed sharing of fiscal sovereignty: the prior approval of debt issuance and ex ante intervention rights into national budgets.

These two instruments are not substitutes but rather complements: Introducing the sharing of sovereignty by two instruments would facilitate the gradual fading-in of the transfer of competences (with a necessary authorisation of debt issuance being a less intrusive instrument than the direct amendment of budgets) and offers in the long-term stronger safeguards against non-compliance than just reliance on one instrument.

Can sharing fiscal sovereignty effectively address the remaining weaknesses of the current framework? Sharing fiscal sovereignty by giving the European centre the right to veto draft budgets and to restrict debt issuance would create effective instruments for situations, in which a country persistently refuses necessary adjustments to its fiscal policy. These instruments therefore heal one central weakness of the current framework.

Second, this sharing of fiscal sovereignty via one or both of these instruments would lead to a fiscal surveillance system, which can effectively prevent the building up of fiscal imbalances ex ante, instead of trying to correct them ex post. This would facilitate the direct enforcement of the numerical benchmarks of the fiscal rules (as e.g. the medium-term budgetary objective of a structurally balanced budget) by the European level and could effectively prevent upward debt trajectories.

To ensure the effectiveness of these instruments it is – also based on the experiences of the current framework – decisive that they are designed to work fairly automatically, avoiding the possibility of lax implementation or political discretion by the Council.

6. CONCLUSIONS

Following the entry into force of the strengthened EU economic governance framework in December 2011, the expected complement of the ‘two-pack’ , the agreement on the TSCG, and the fiscal compact in particular, constitute welcome steps towards a stronger rule-based EU fiscal governance framework.

However, the reforms fall short of a quantum leap even in the “Maastricht World” (with ultimate national responsibility for fiscal policies). The framework remains vulnerable especially because a lack of sufficient automaticity in the procedures of the SGP in case of non-compliance with the rules, a lot of room for political discretion and the failure to effectively prevent upward debt trajectories (treating past deficits above the numerical benchmarks and past slippages as bygones).

Looking further ahead, ambitious steps towards improving the EU fiscal framework, in particular for euro area countries, will be necessary to address the remaining shortcomings. Here a qualitative move towards a fiscal union is necessary to ensure sound fiscal policies and make the fiscal framework fully commensurate to the requirements of the single currency (see also Van Rompuy, 2012). At the core of such a move is the further sharing of fiscal sovereignty, accompanied where necessary by a change in the Treaty. This means that the ultimate authority to decide on fiscal policy lies no longer at the national, but at the European level.

REFERENCES

Abbott KW, Snidal D (2000) Hard and Soft Law in International Governance. *International Organisation* 54:421–56

Amténbrink, F., J. de Haan and O.C.H.M. Sleijpen (1997), ‘Stability and Growth Pact: Placebo or Panacea?’, *European Business Law Review*, 202-210 and 223-238.

Artis, M.J. (2002), ‘The Stability and Growth Pact: Fiscal Policy in the EMU’, in F. Breuss, Fink, G. and S. Griller (eds.), *Institutional, Legal and Economic Aspects of the EMU*, Springer, Wien-New York.

Artis, M.J. and M. Buti (2000), ‘Close to Balance or In Surplus’ - A Policy Maker’s Guide to the Implementation of the Stability and Growth Pact’, *Journal of Common Market Studies*, 38(4): 563-92.

Balassone, F. and D. Franco (1999), ‘Fiscal Federalism and the Stability and Growth Pact: A Difficult Union’, *Journal of Public Finance and Public Choice*, XVII(2-3): 135-163.

Beetsma, R. and A.L. Bovenberg (1998), ‘Monetary Union without Fiscal Coordination May Discipline Policymakers’, *Journal of International Economics*, 45: 239-58.

- Beetsma, R., M. Giuliodori and P. Wiertz (2009): “Planning to cheat: EU fiscal policy in real time”, *Economic Policy* 24;
- Brunila, A., M. Buti and D. Franco (eds.) (2001), *The Stability and Growth Pact – The Architecture of Fiscal Policy in EMU*, Palgrave, Basingstoke.
- Buti, M. and B. Martinot (2000), ‘Open Issues in the Implementation of the Stability and Growth Pact’, *National Institute Economic Review*, 174: 92-104.
- Buti, M. and G. Giudice (2002), ‘Maastricht’s Fiscal Rules at Ten: An Assessment’, *Journal of Common Market Studies*, 40(5): 823-47.
- Buti, M., Eijffinger, S. and Franco, D. (2003), “Revisiting the Stability and Growth Pact: grand
- Buti, M., Franco, D. and H. Ongena (1997), ‘Budgetary Policies During Recessions – Retrospective Application of the Stability and Growth Pact to the Post-War Period’, *Recherches Economiques de Louvain*, 63, 4: 321-66.
- Calmfors, L. (2005), “What remains of the Stability Pact and what next?”, *SIEPS Reports*, No 8, Swedish Institute for European Policy Studies, November.
- Commission, January.
- Debrun, X. and M.S. Kumar (2007): “The discipline-enhancing role of fiscal institutions: theory and empirical evidence”, IMF Working Paper 07/171,
- design or internal adjustment?”, *European Economy – Economic Papers*, No 180, European
- EU Council (2012), ‘Press release on the 3148th Council meeting on Economic and Financial Affairs’, Brussels, 21 February.
- European Central Bank (2004), “EMU and the conduct of fiscal policies”, *Monthly Bulletin*, January.
- European Central Bank (2008), ‘One monetary policy and many fiscal policies: ensuring a smooth functioning of EMU’, *Monthly Bulletin*, July.
- European Central Bank (2008), “Ten years of the Stability and Growth Pact”, *Monthly Bulletin*, October.
- European Central Bank (2011), ‘The reform of economic governance in the euro area – essential elements’, *Monthly Bulletin*, March , pp. 99-119.
- European Central Bank (2012a), ‘Opinion on strengthened economic governance of the euro area’, CON/2012/18, 7 March.
- European Central Bank (2012b), ‘A fiscal compact for a stronger economic and monetary union’, *Monthly Bulletin*, May, pp. 79-94.
- European Central Bank Monthly Bulletin (1999): “The Implementation of the Stability And Growth Pact”, Frankfurt
- European Commission (2011a), ‘Proposal for a Regulation of the European Parliament and of the Council on common provisions for monitoring and assessing draft budgetary plans and ensuring the correction of excessive deficit of the Member States in the euro area’, COM(2011) 821, 23 November.
- European Commission (2011b), ‘Proposal for a Regulation of the European Parliament and of the Council on the strengthening of economic and budgetary surveillance of Member States experiencing or threatened with serious difficulties with respect to their financial stability in the euro area’, COM(2011) 819, 23 November.
- European Commission (2012), ‘Communication on common principles on national fiscal correction mechanisms’, COM(2012) 342, 20 June.
- European Court of Justice (2012), Judgement in the Pringle case.
- European Parliament (2012a), ‘Amendments to the Commission proposal for a Regulation of the European Parliament and of the Council on common provisions for monitoring and assessing draft budgetary plans and ensuring the correction of excessive deficit of the Member States in the euro area’, 13 June.

European Parliament (2012b), 'Amendments to the Commission proposal for a Regulation of the European Parliament and of the Council on the strengthening of economic and budgetary surveillance of Member States experiencing or threatened with serious difficulties with respect to their financial stability in the euro area', 13 June.

Fatas A, von Hagen J, Hallett AH, Strauch RR, Sibert A (2003) Stability and Growth Pact in Europe: Towards a Better Pact. Monitoring European Integration 13, Bonn/London: ZEI/CEPR

Fischer, J., Jonung, L. and Larch, M. (2006), "101 proposals to reform the Stability and Growth Pact. Why so many? A Survey", *European Economy – Economic Papers*, No 267, European Commission, December.

Frankel, J. (2011): "Over-optimism in forecasts by official budget agencies and its implications", NBER Working Paper No. 17239.

Haan, J. de and J.E. Sturm (1994), 'Political and Institutional Determinants of Fiscal Policy in the European Community', *Public Choice*, 80: 157-172.

Hagemann, R. (2011), 'How can fiscal councils strengthen fiscal performance?', *OECD Journal: Economic Studies*, Vol. 2011/1, pp. 75-98.

Inman, R.P. (1996), 'Do Balanced Budget Rules Work? U.S. Experience and possible Lessons for the EMU', *NBER Working Paper Series*, 5838.

Kopits, G. and S. Symansky (1998), 'Fiscal Policy Rules', *IMF Occasional Paper*, No. 162.

Morris, R., Ongena, H. and Schuknecht, L. (2006), "The reform and implementation of the Stability and Growth Pact", *Occasional Paper Series*, No 47, European Central Bank, June.

Schaechter et al. (2012): "Fiscal rules in response to the crisis—toward the 'Next-generation' rules. A new dataset", IMF Working Paper 187.

Schuknecht, L. (2005), "Stability and Growth Pact: issues and lessons from political economy", *International Economics and Economic Policy*, Vol. 2, No 1, October.

Schuknecht, L., P. Moutot, P. Rother and J. Stark (2011), "The Stability and Growth Pact: crisis and reform", ECB Occasional Paper, No. 129, September.

Schure, P. and Verdun, A. (2008) 'Legislative Bargaining in the European Union: The Divide between Large and Small Member States'. *European Union Politics*, Vol. 9, No. 4, pp. 459–86.

Stark, J. (2001), "Genesis of a pact", in Brunila, A., Buti, M. and Franco, D. (eds.), *The Stability and Growth Pact – the architecture of fiscal policy in EMU*, Palgrave.

Strauch, R. and J. von Hagen (eds.) (2000), *Institutions, Politics and Fiscal Policy*, Dordrecht, Kluwer Academic Publishers.

Strauch, R. and J. von Hagen (eds.) (2000), *Institutions, Politics and Fiscal Policy*, Dordrecht, Kluwer Academic Publishers.

von Hagen, J. (2010): "Sticking to fiscal plans: the role of institutions", *Public Choice* 144;

Van Riet, A. (ed.) (2010), 'Euro area fiscal policies and the crisis', *ECB Occasional Paper*, No. 109, Frankfurt am Main, April.

Van Rompuy (2012), *Towards a genuine Economic and Monetary Union*, Report by the President of the European Council prepared in close cooperation with the Presidents of the European Commission, the Eurogroup and the European Central Bank, Brussels, 26 June.

Wyplosz, C., (2012): "Fiscal rules: theoretical issues and historical experiences", NBER WP 17884